

P-9187

X1172

SCALE 1:1

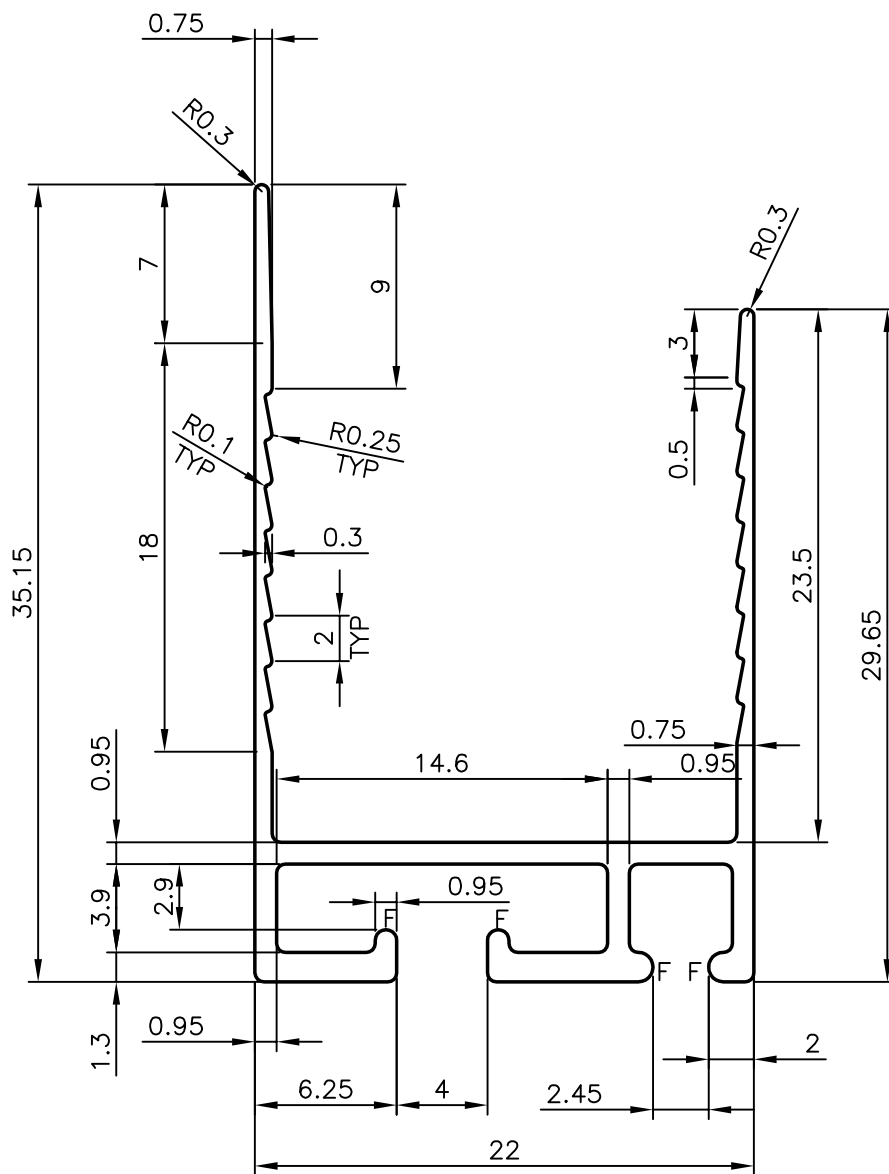

NOTE:-

1. F = FULL RADIUS (4 PLACES)



SYMBOL OF QUALITY
AN ISO 9001 COMPANY

JINDAL ALUMINIUM LTD.
BANGALORE-560073 (INDIA)

	NAME	DATE
DRAWN	J.P.KAUSHIK	29-04-2009
CHECKED		
APPROVED		

1. ALL DIMENSIONS ARE IN mm.
2. ROUND OFF ALL SHARP CORNERS WITH 0.50 mm.
3. TOLERANCES WILL BE AS PER BS:EN-755 UNLESS OTHERWISE SPECIFIED

SCALE	3:1
AREA mm ²	87.769
PERIMETER mm.	208.901
WEIGHT kg/m	0.237

PARTY'S NAME	FAISAL JASSIM INDUSTRIES., DUBAI
PARTY'S DRAWING No.	WM147C
ALLOY & TEMPER	6063 T6
DESCRIPTION	MISC. SECTION

DRAWING No.	SECTION No.
P-9187	-
X1172	X1172