

P-9190

X1175

SCALE 1:1

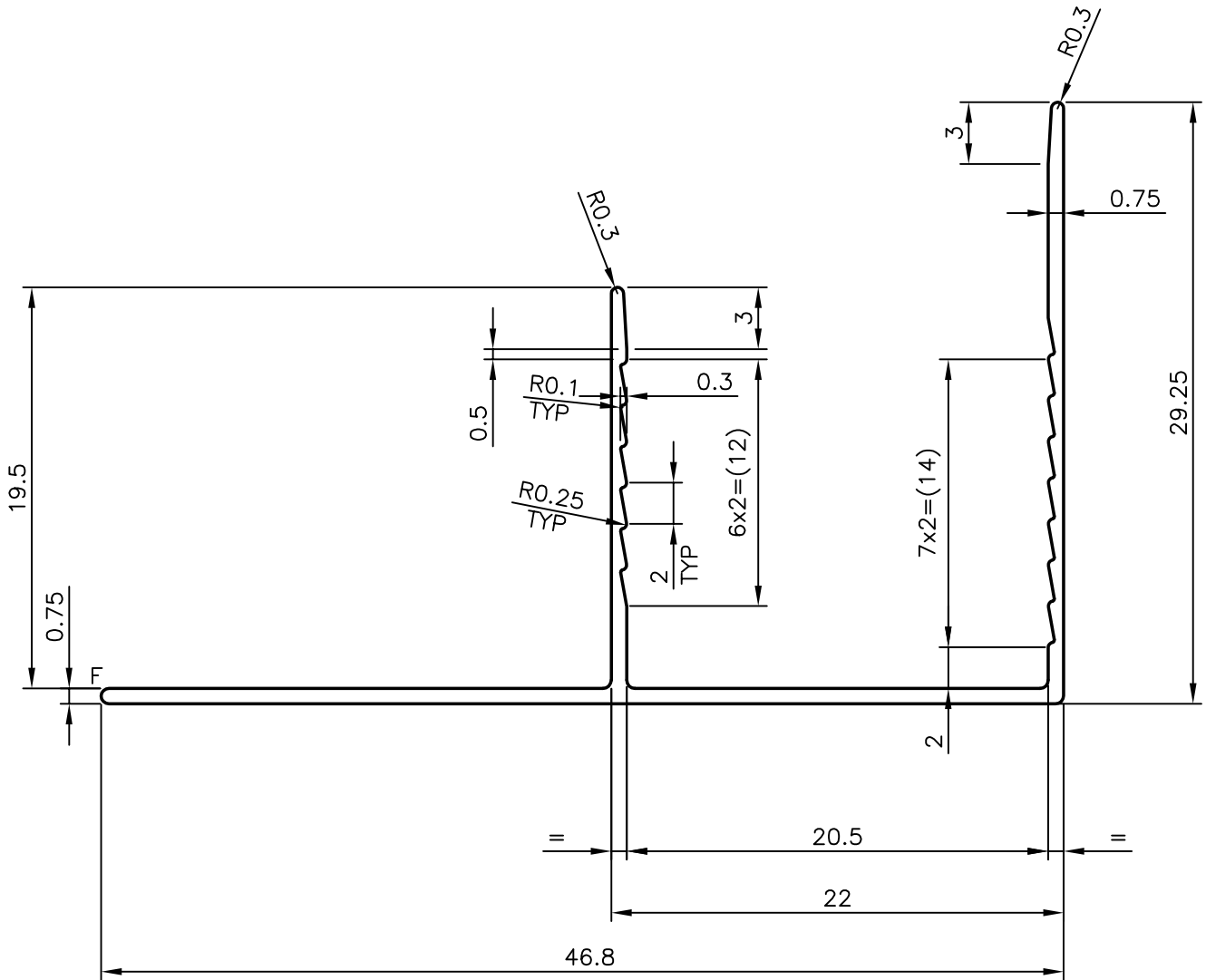

NOTE:-
1. F = FULL RADIUS



SYMBOL OF QUALITY
AN ISO 9001 COMPANY

JINDAL ALUMINIUM LTD.
BANGALORE-560073 (INDIA)

	NAME	DATE
DRAWN	J.P.KAUSHIK	29-04-2009
CHECKED		
APPROVED		
SCALE		3:1
AREA mm ²		67.277
PERIMETER mm.		193.812
WEIGHT kg/m		0.182
DRAWING No.	SECTION No.	
P-9190	-	
X1175	X1175	

1. ALL DIMENSIONS ARE IN mm.
2. ROUND OFF ALL SHARP CORNERS WITH 0.40 mm.
3. TOLERANCES WILL BE AS PER BS:EN-755 UNLESS OTHERWISE SPECIFIED

PARTY'S NAME	FAISAL JASSIM INDUSTRIES., DUBAI
PARTY'S DRAWING No.	WM148
ALLOY & TEMPER	6063 T6
DESCRIPTION	MISC. SECTION