

P-9406-2

X1193

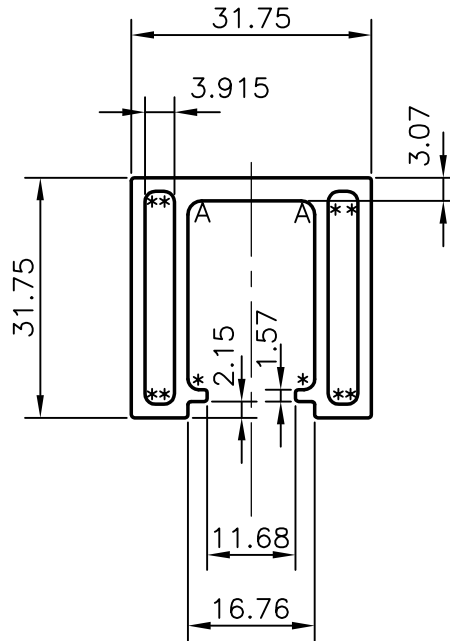

1. GENERAL WALL THICKNESS:- 1.79 mm.
2. A = 1.80 RADIUS (2)
3. \* = 1.40 RADIUS (10)



SYMBOL OF QUALITY  
AN ISO 9001 COMPANY

**JINDAL ALUMINIUM LTD.**  
BANGALORE-560073 (INDIA)

	NAME	DATE
DRAWN	RAGHAVENDRA	21-07-2009
CHECKED		
APPROVED		
SCALE		1:1
AREA mm <sup>2</sup>		320.112
PERIMETER mm.		189.713
WEIGHT kg/m		0.864
DRAWING No.	SECTION No.	
P-9406-2	-	
X1193	X1193	

1. ALL DIMENSIONS ARE IN mm.
2. ROUND OFF ALL SHARP CORNERS WITH 0.40 mm.
3. TOLERANCES WILL BE AS PER BS:EN-755 UNLESS OTHERWISE SPECIFIED

PARTY'S NAME	PROSOURCE INDUSTRIAL SOLUTIONS, CANADA
PARTY'S DRAWING No.	AS PER DRAWING
ALLOY & TEMPER	6063 T6
DESCRIPTION	HAND RAIL SECTION