

P-9453

X1203

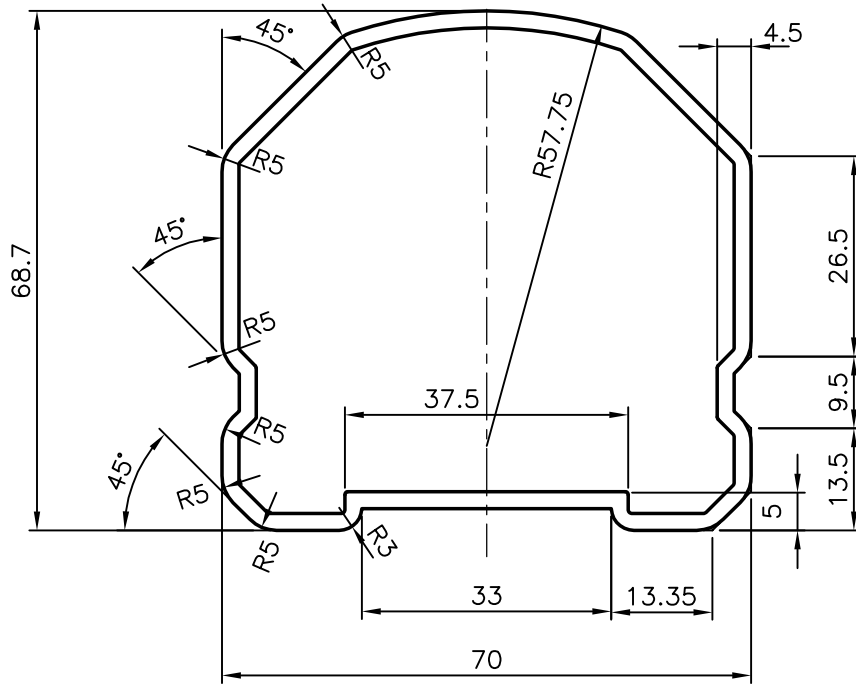

GENERAL WALL THICKNESS:- 2.25 mm.



SYMBOL OF QUALITY
AN ISO 9001 COMPANY

JINDAL ALUMINIUM LTD.
BANGALORE-560073 (INDIA)

	NAME	DATE
DRAWN	J.P.KAUSHIK	31-08-2009
CHECKED		
APPROVED		

1. ALL DIMENSIONS ARE IN mm.
2. ROUND OFF ALL SHARP CORNERS WITH 0.4mm.
3. TOLERANCES WILL BE AS PER BS:EN-755 UNLESS OTHERWISE SPECIFIED

SCALE	1:1
AREA mm ²	551.404
PERIMETER mm.	251.581
WEIGHT kg/m	1.489

PARTY'S NAME: PROSOURCE INDUSTRIAL SOLUTIONS INC.

DRAWING No. SECTION No.

PARTY'S DRAWING No.: AS PER SAMPLE

P-9453

-

ALLOY & TEMPER: 6063 T6

X1203

X1203

DESCRIPTION: HAND RAIL SECTION