

P-9602

X1228

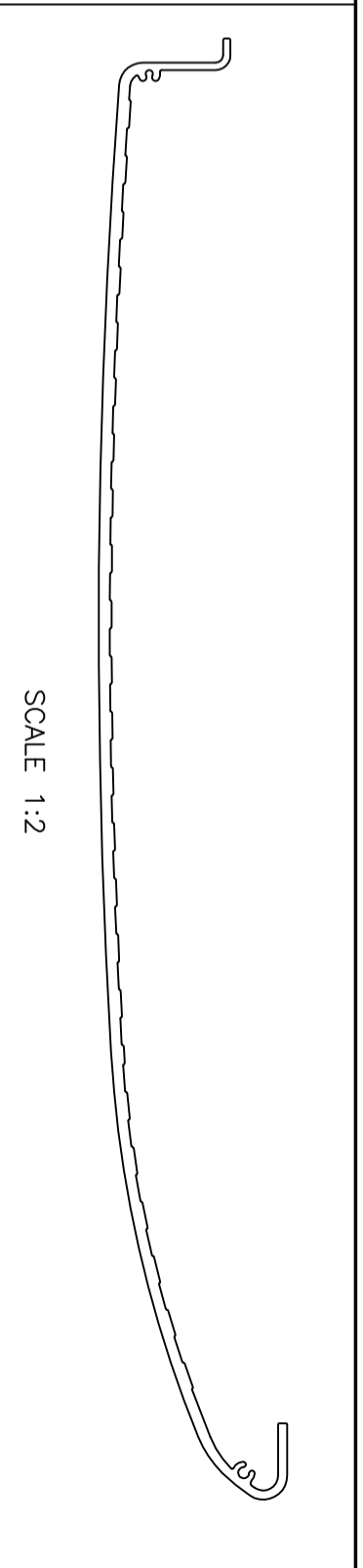

SCALE 1:2

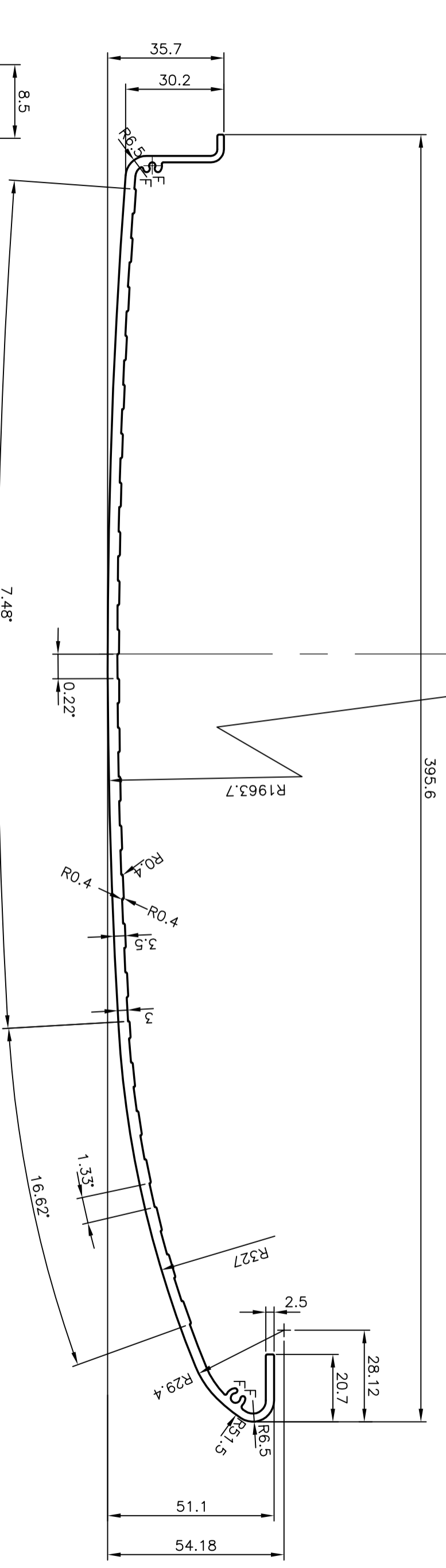

F = FULL RADIUS (4 PLACES)

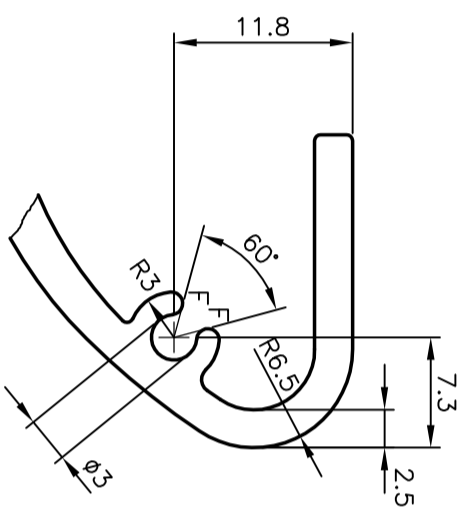
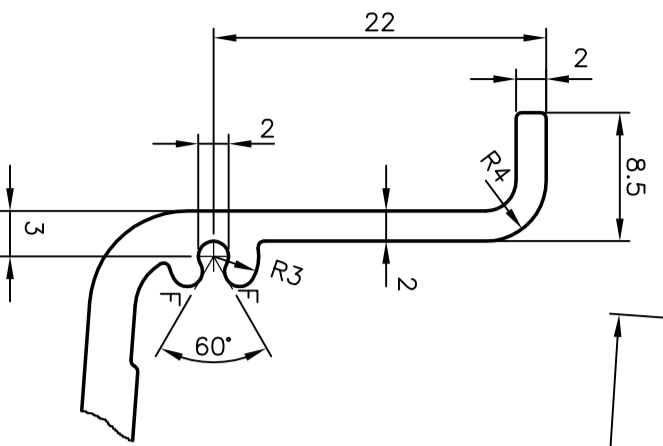

 <p>JINDAL ALUMINIUM LTD. BANGALORE-560073 (INDIA)</p>		NAME	DATE
		DRAWN	J.P. KAUSHIK 03-11-2009
<p>1. ALL DIMENSIONS ARE IN mm. 2. ROUND OFF ALL SHARP CORNERS WITH 0.40 mm. 3. TOLERANCES WILL BE AS PER IS:3965-1981 UNLESS OTHERWISE SPECIFIED</p>		CHECKED	
		APPROVED	
PARTY'S NAME		VOLVO BUSES INDIA PVT. LTD., BANGALORE	
PARTY'S DRAWING No.		703735559	
ALLOY & TEMPER		6060 T6	
DESCRIPTION		TRANSPORT SECTION	
SCALE		1:0.75	
AREA mm ²		1408.611	
PERIMETER mm.		931.727	
WEIGHT kg/m		3.803	
DRAWING No.		SECTION No.	
P-9602		-	
X1228		X1228	