

P-7688

X1260

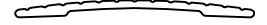

1:1

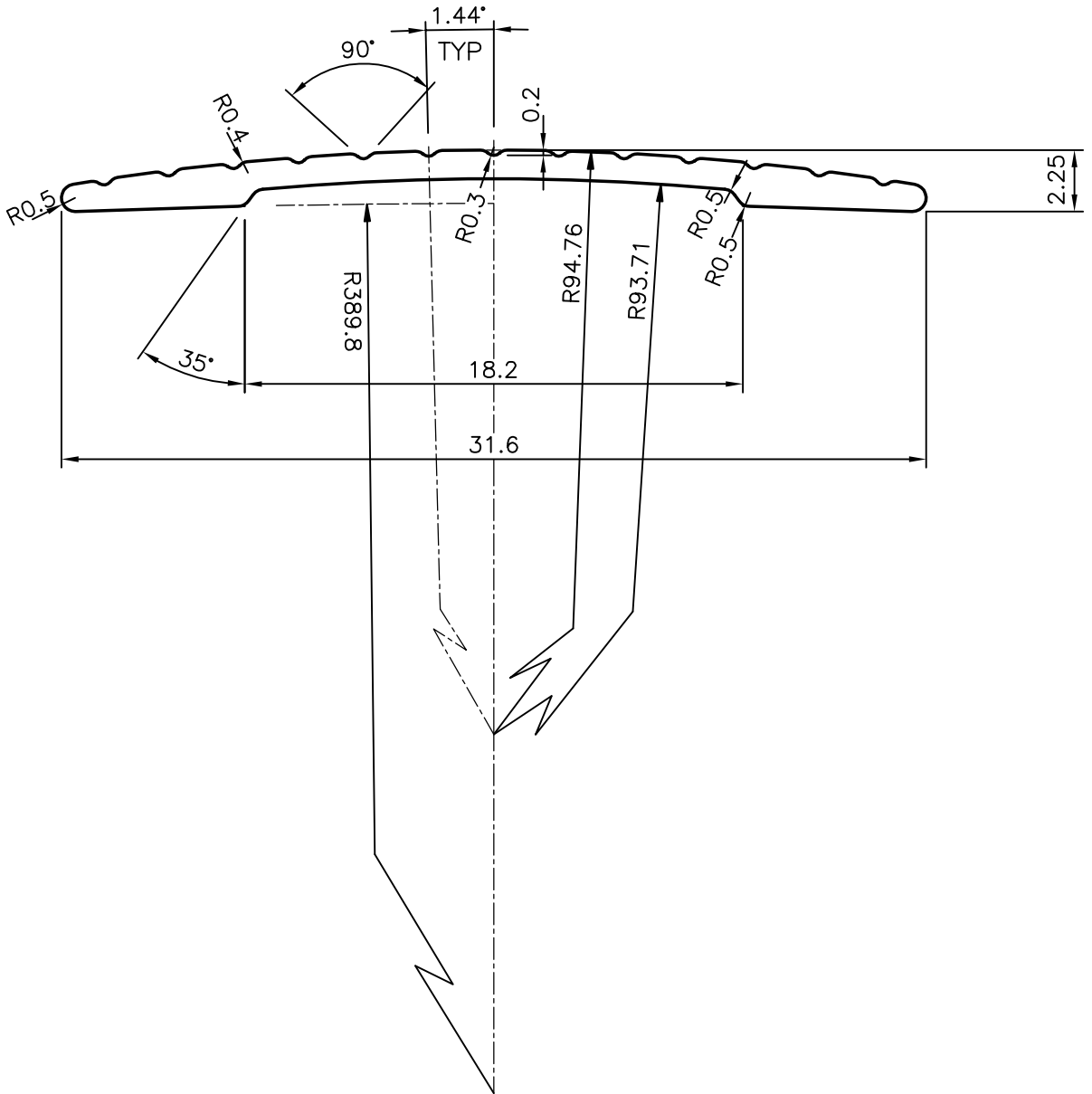

SYMBOL OF QUALITY
AN ISO 9001 COMPANY

JINDAL ALUMINIUM LTD.
BANGALORE-560073 (INDIA)

	NAME	DATE
DRAWN	J.P.KAUSHIK	17-11-2007
CHECKED		
APPROVED	S.S.GARG	26-02-2010
SCALE		4:1
AREA mm ²		35.609
PERIMETER mm.		66.595
WEIGHT kg/m		0.096

1. ALL DIMENSIONS ARE IN mm.
2. ROUND OFF ALL SHARP CORNERS WITH 0.40 mm.
3. TOLERANCES WILL BE AS PER BS:EN-755 UNLESS OTHERWISE SPECIFIED

PARTY'S NAME	ROBUSTLINE GEN.TRDG.CO.LTD.,UAE.
PARTY'S DRAWING No.	AS PER SAMPLE
ALLOY & TEMPER	6063 T6
DESCRIPTION	CARPET EDGE SECTION

DRAWING No.	SECTION No.
P-7688	-
X1260	X1260