

P-9612

X1262

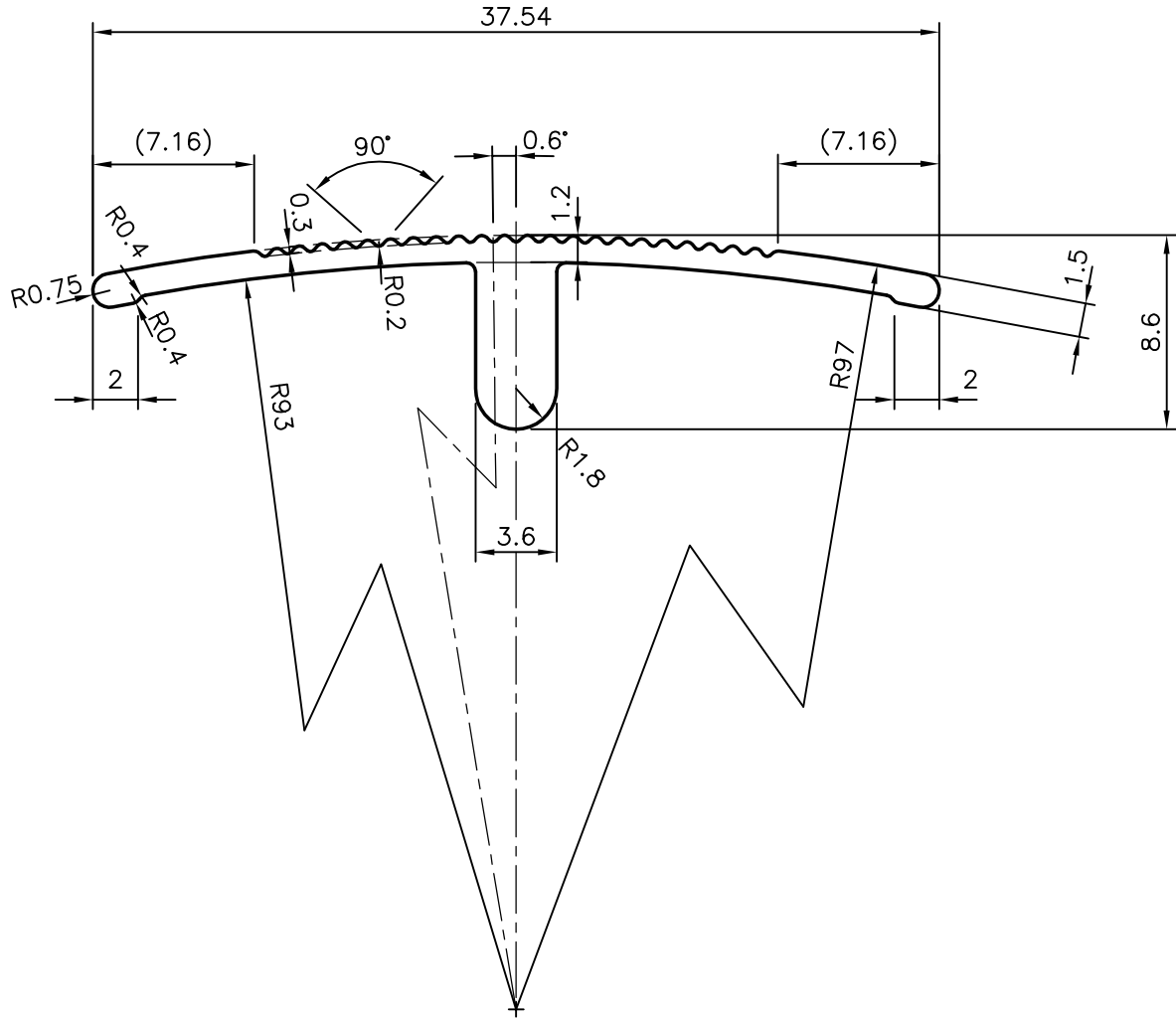
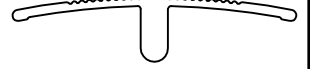

SYMBOL OF QUALITY
AN ISO 9001 COMPANY

JINDAL ALUMINIUM LTD.
BANGALORE-560073 (INDIA)

	NAME	DATE
DRAWN	J.P.KAUSHIK	04-11-2009
CHECKED		
APPROVED	S.S.GARG	26-02-2010
SCALE		3:1
AREA mm ²		68.608
PERIMETER mm.		95.023
WEIGHT kg/m		0.185

1. ALL DIMENSIONS ARE IN mm.
2. ROUND OFF ALL SHARP CORNERS WITH 0.40 mm.
3. TOLERANCES WILL BE AS PER BS:EN-755 UNLESS OTHERWISE SPECIFIED

PARTY'S NAME	ROBUSTLINE GEN.TRDG.CO.LTD.,UAE.
PARTY'S DRAWING No.	AS PER SAMPLE
ALLOY & TEMPER	6063 T6
DESCRIPTION	MISC. SECTION

DRAWING No.	SECTION No.
P-9612	-
X1262	X1262