

P-10089-1

X1312

EXPOSED SURFACE

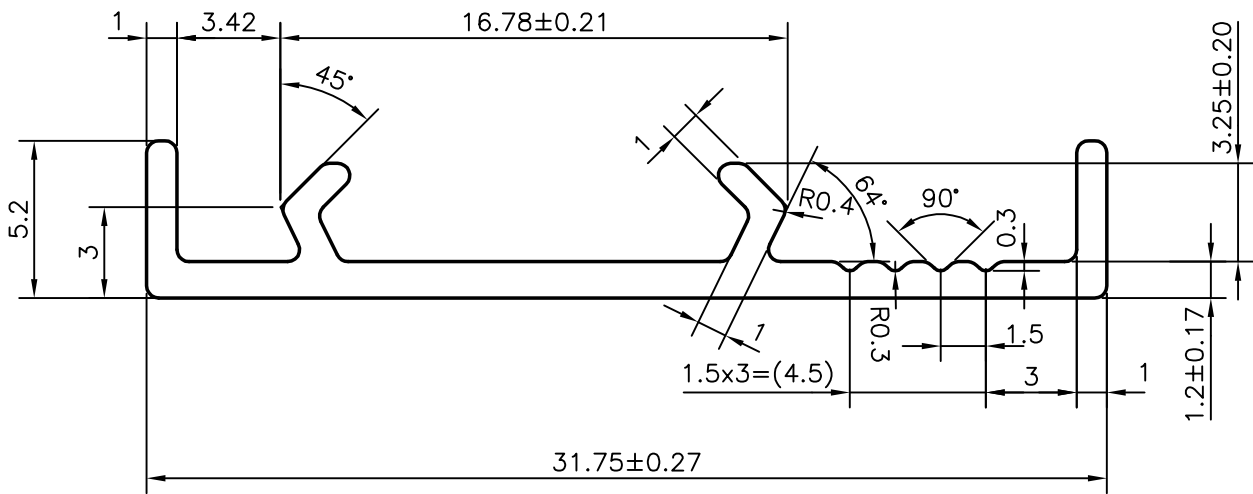
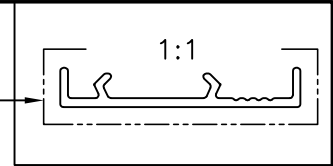

FLATNESS :- ±0.25 mm



SYMBOL OF QUALITY  
AN ISO 9001 COMPANY

**JINDAL ALUMINIUM LTD.**  
BANGALORE-560073 (INDIA)

	NAME	DATE
DRAWN	J.P.KAUSHIK	08-06-2010
CHECKED		
APPROVED		

1. ALL DIMENSIONS ARE IN mm.
2. ROUND OFF ALL SHARP CORNERS WITH 0.40 mm.
3. TOLERANCES WILL BE AS PER BS:EN-755 UNLESS OTHERWISE SPECIFIED

SCALE	4:1
AREA mm <sup>2</sup>	53.267
PERIMETER mm.	94.859
WEIGHT kg/m	0.144

PARTY'S NAME	KOMFORT OFFICE ENVIRONMENTS PLC., U.K.
PARTY'S DRAWING No.	TF279
ALLOY & TEMPER	6063 T6
DESCRIPTION	COVER STRIP SECTION

DRAWING No.	SECTION No.
P-10089-1	
X1312	X1312