

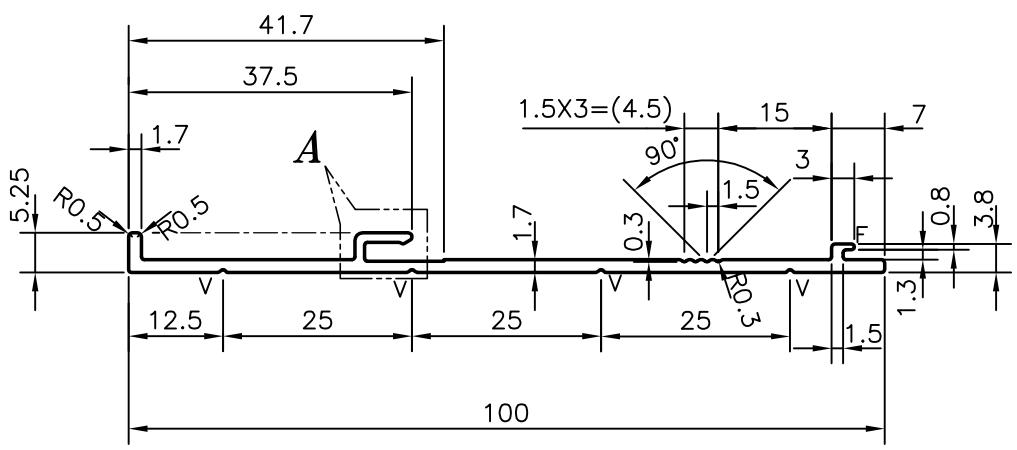

P-10090-1
X1313

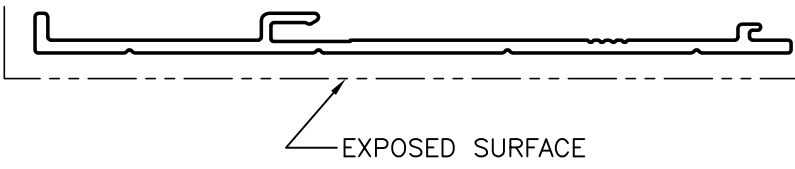

DETAIL "A"

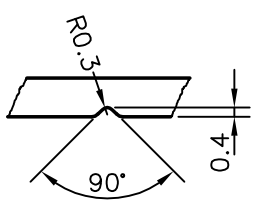
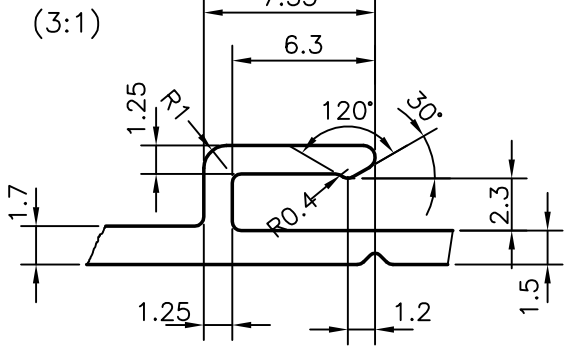

F = FULL RADIUS
V = VGROOVE 0.4x90° (4)

 SYMBOL OF QUALITY AN ISO 9001 COMPANY	JINDAL ALUMINIUM LTD. BANGALORE-560073 (INDIA)	NAME		DATE
		DRAWN	J.P.KAUSHIK	09-06-2010
1. ALL DIMENSIONS ARE IN mm. 2. ROUND OFF ALL SHARP CORNERS WITH 0.40 mm. 3. TOLERANCES WILL BE AS PER BS:EN-755 UNLESS OTHERWISE SPECIFIED		CHECKED		
		APPROVED	S.S.GARG	15-06-2010
PARTY'S NAME KOMFORT OFFICE ENVIRONMENTS PLC., U.K.		SCALE		1:1
		AREA mm ²		188.449
PARTY'S DRAWING No. TF296		PERIMETER mm.		236.003
		WEIGHT kg/m		0.509
ALLOY & TEMPER 6063 T6		DRAWING No.		P-10090-1
		SECTION No.		X1313
DESCRIPTION 100mm ALUMINIUM SKIRTING		X1313		X1313