

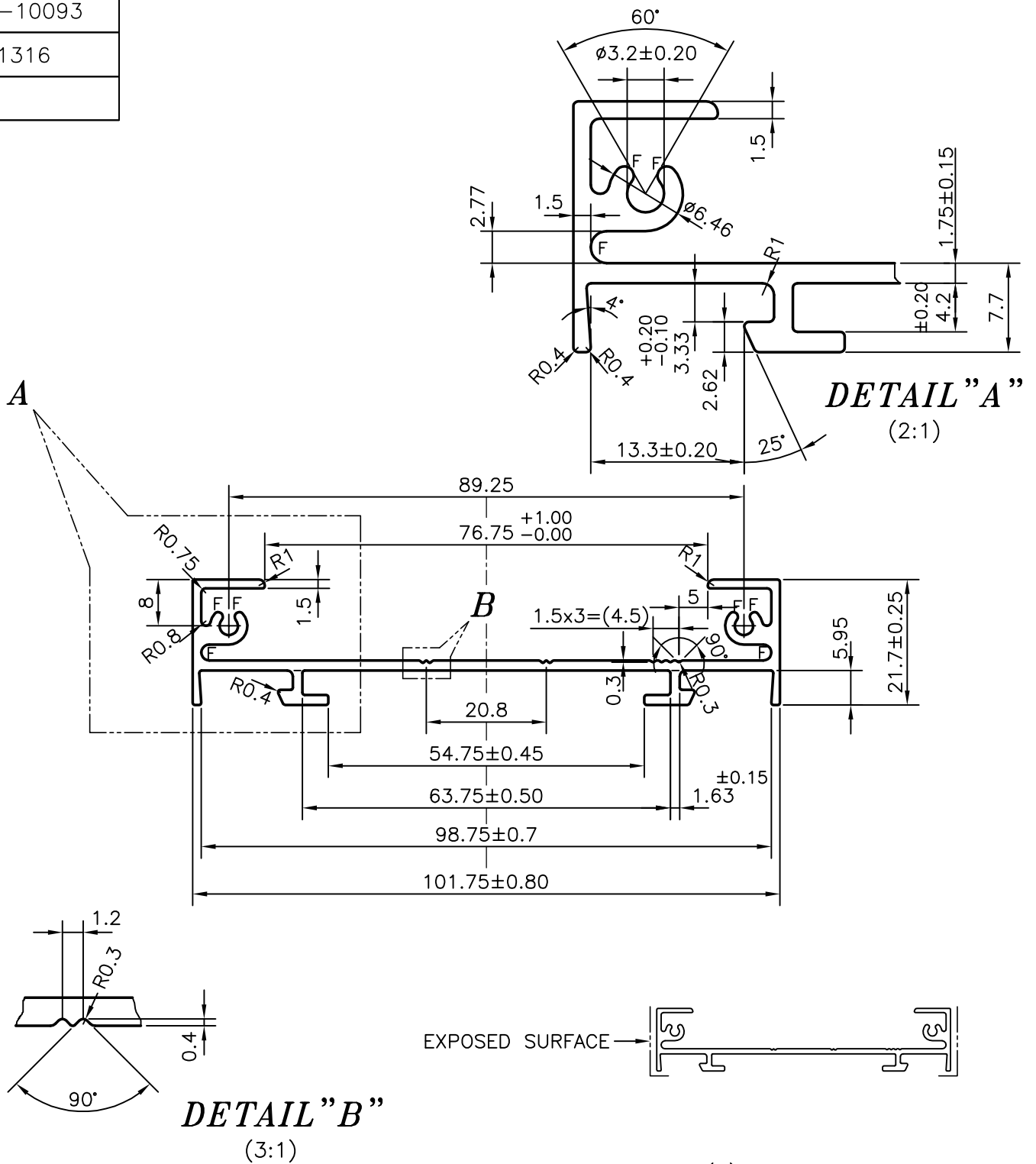

P-10093

X1316



 SYMBOL OF QUALITY AN ISO 9001 COMPANY	JINDAL ALUMINIUM LTD. BANGALORE-560073 (INDIA)	NAME	DATE
		DRAWN	J.P.KAUSHIK 09-06-2010
		CHECKED	
		APPROVED	S.S.GARG 15-06-2010
1. ALL DIMENSIONS ARE IN mm. 2. ROUND OFF ALL SHARP CORNERS WITH 0.40 mm. 3. TOLERANCES WILL BE AS PER BS:EN-755 UNLESS OTHERWISE SPECIFIED		SCALE	1:1
		AREA mm ²	370.023
		PERIMETER mm.	424.264
PARTY'S NAME	KOMFORT OFFICE ENVIRONMENTS PLC., U.K.	WEIGHT kg/m	0.999
PARTY'S DRAWING No.	TF440	DRAWING No.	SECTION No.
ALLOY & TEMPER	6063 T6	P-10093	
DESCRIPTION	102 mm VERTICAL/HEAD DOUBLE GLAZING	X1316	X1316