

P-10171

X1329

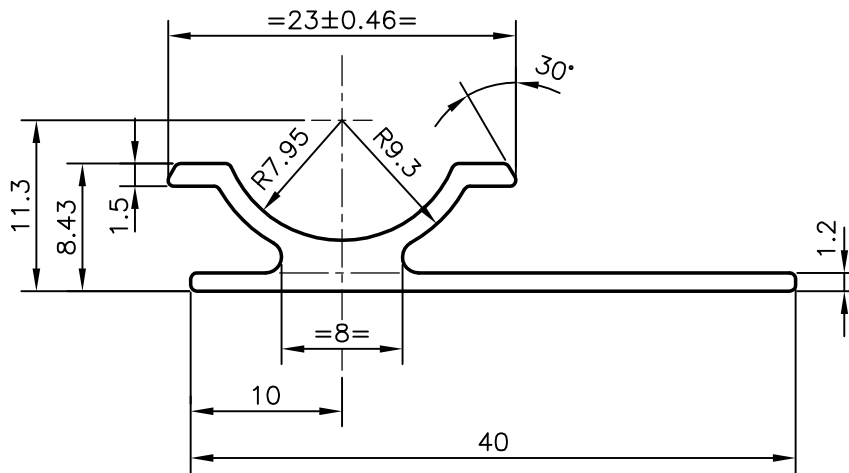
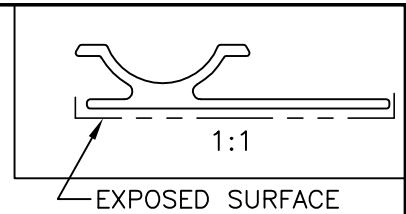

SYMBOL OF QUALITY
AN ISO 9001 COMPANY

JINDAL ALUMINIUM LTD.
BANGALORE-560073 (INDIA)

	NAME	DATE
DRAWN	J.P.KAUSHIK	08-07-2010
CHECKED		
APPROVED	S.S.GARG	10-07-2010
SCALE		2:1
AREA mm ²		94.095
PERIMETER mm.		123.156
WEIGHT kg/m		0.254
DRAWING No.	SECTION No.	
P-10171	-	
X1329	X1329	

1. ALL DIMENSIONS ARE IN mm.
2. ROUND OFF ALL SHARP CORNERS WITH 0.40 mm.
3. TOLERANCES WILL BE AS PER BS:EN-12020-2 UNLESS OTHERWISE SPECIFIED

PARTY'S NAME	PROSOURCE INDUSTRIAL SOLUTIONS, CANADA
PARTY'S DRAWING No.	671762
ALLOY & TEMPER	6063 T5
DESCRIPTION	MISC. SECTION