

P-10170

X1340

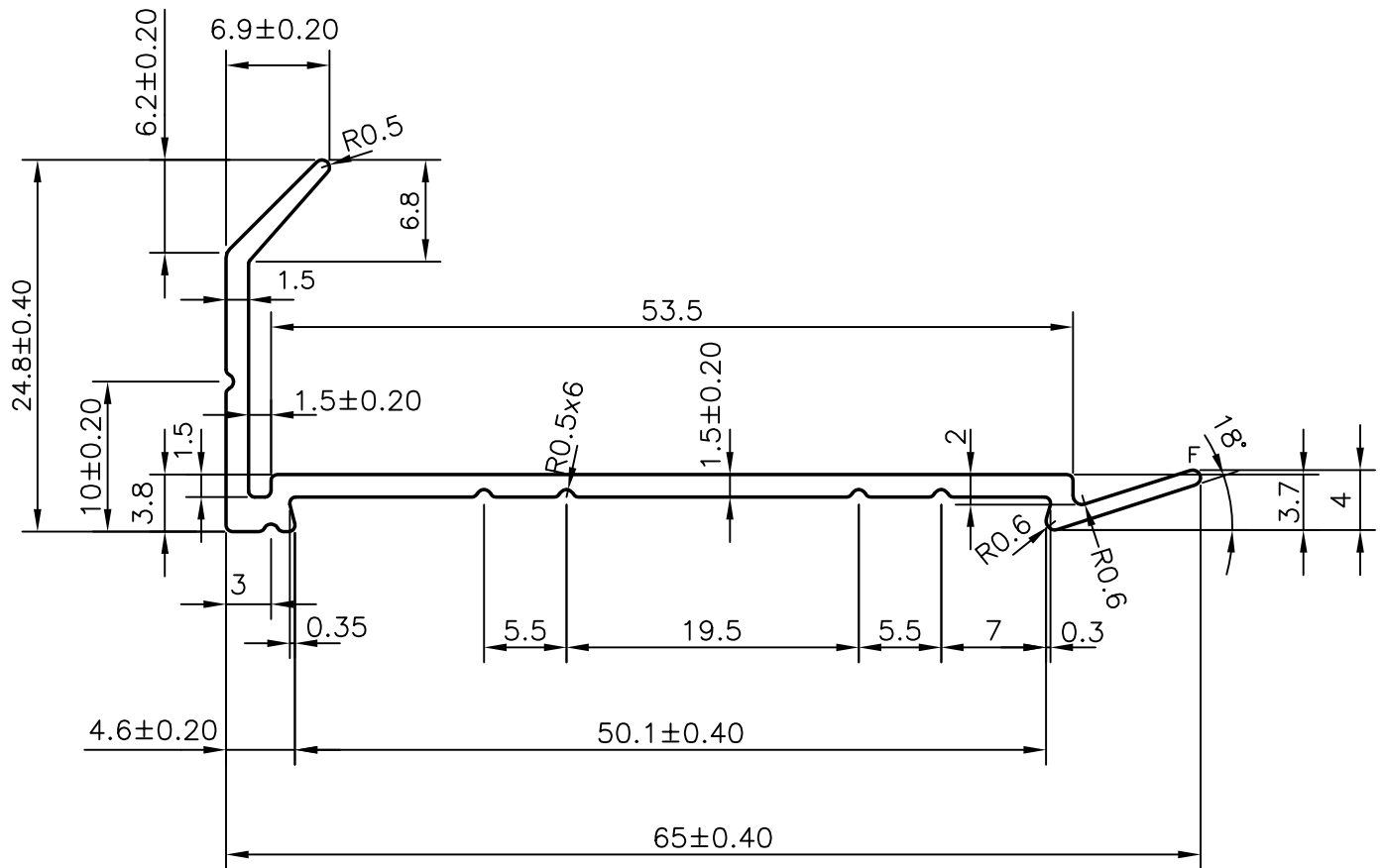
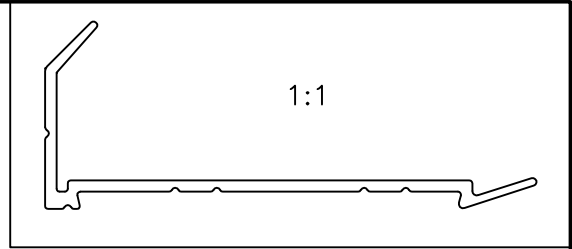

F = FULL RADIUS

PERMANENT EXCLUSIVE



SYMBOL OF QUALITY
AN ISO 9001 COMPANY

JINDAL ALUMINIUM LTD.
BANGALORE-560073 (INDIA)

	NAME	DATE
DRAWN	J.P.KAUSHIK	08-07-2010
CHECKED		
APPROVED	S.S.GARG	18-08-2010

1. ALL DIMENSIONS ARE IN mm.
2. ROUND OFF ALL SHARP CORNERS WITH 0.40 mm.
3. TOLERANCES WILL BE AS PER BS:EN-12020-2 UNLESS OTHERWISE SPECIFIED

SCALE	2:1
AREA mm ²	135.291
PERIMETER mm.	191.381
WEIGHT kg/m	0.365

PARTY'S NAME VOLVO BUSES INDIA PVT. LTD., BANGALORE

PARTY'S DRAWING No. 21474594 REV.01

ALLOY & TEMPER 6005 T6

DESCRIPTION STEP EDGE BEADING

DRAWING No.	SECTION No.
P-10170	-
X1340	X1340