

P-10339

X1353

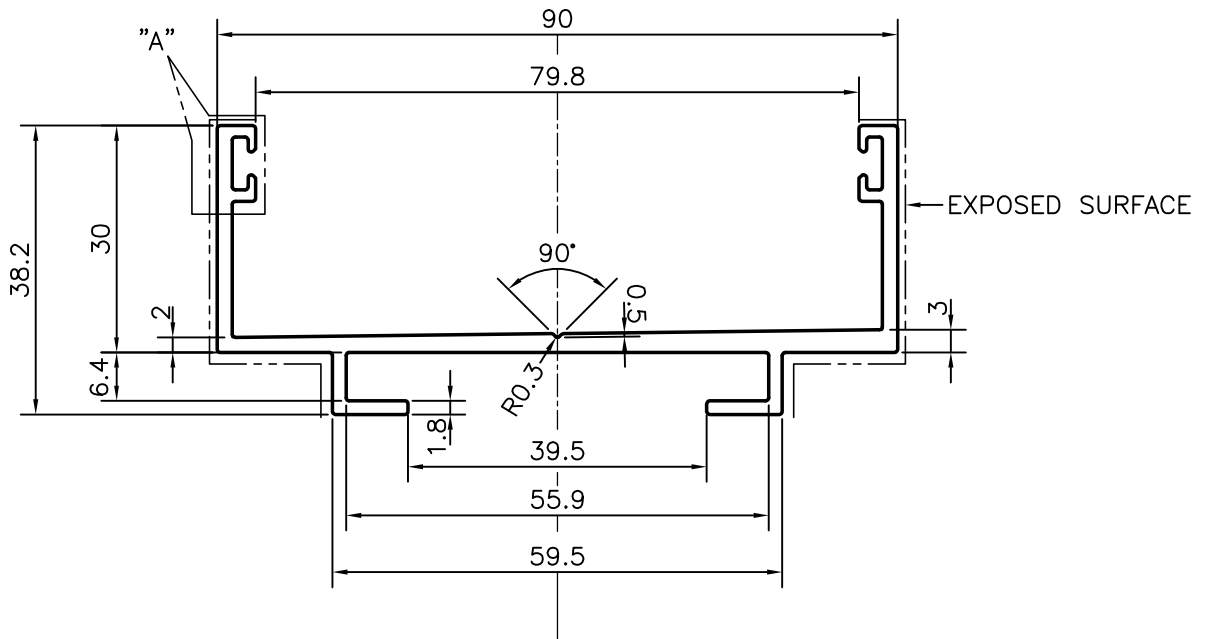

PERMANENT EXCLUSIVE

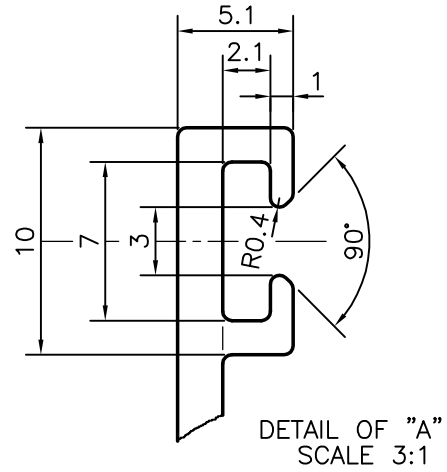

SYMBOL OF QUALITY
AN ISO 9001 COMPANY

JINDAL ALUMINIUM LTD.
BANGALORE-560073 (INDIA)

	NAME	DATE
DRAWN	J.P.KAUSHIK	21-08-2010
CHECKED		
APPROVED	S.S.GARG	10-09-2010
SCALE		1:1
AREA mm ²		419.272
PERIMETER mm.		393.693
WEIGHT kg/m		1.132

1. ALL DIMENSIONS ARE IN mm.
2. ROUND OFF ALL SHARP CORNERS WITH 0.50 mm.
3. TOLERANCES WILL BE AS PER IS:3965-1981 UNLESS OTHERWISE SPECIFIED

PARTY'S NAME	ALUPRO BUILDING SYSTEMS.PVT.LTD.,BANGALORE	DRAWING No.	P-10339	SECTION No.	-
PARTY'S DRAWING No.	AS PER DRAWING		X1353		X1353
ALLOY & TEMPER	HE9 WP				
DESCRIPTION	WINDOW BOTTOM SUB FRAME SECTION				