

P-10340-1

X1354

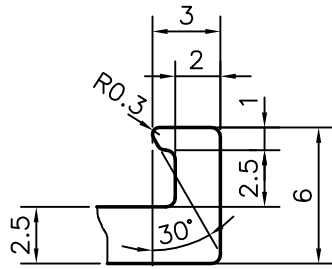

DETAIL OF "B"  
SCALE 3:1

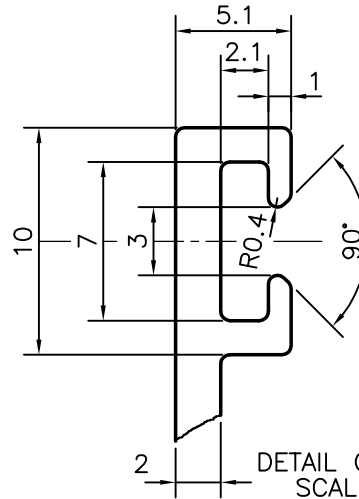

DETAIL OF "A"  
SCALE 3:1

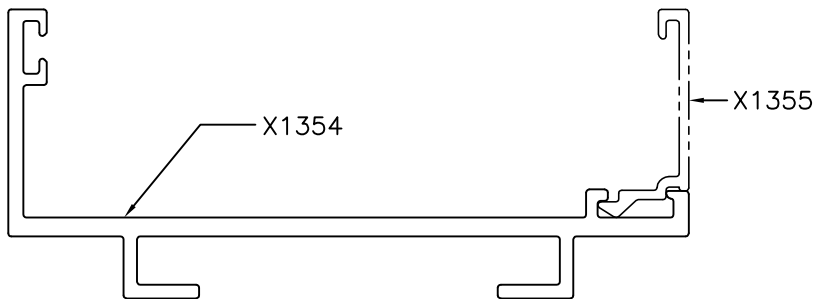
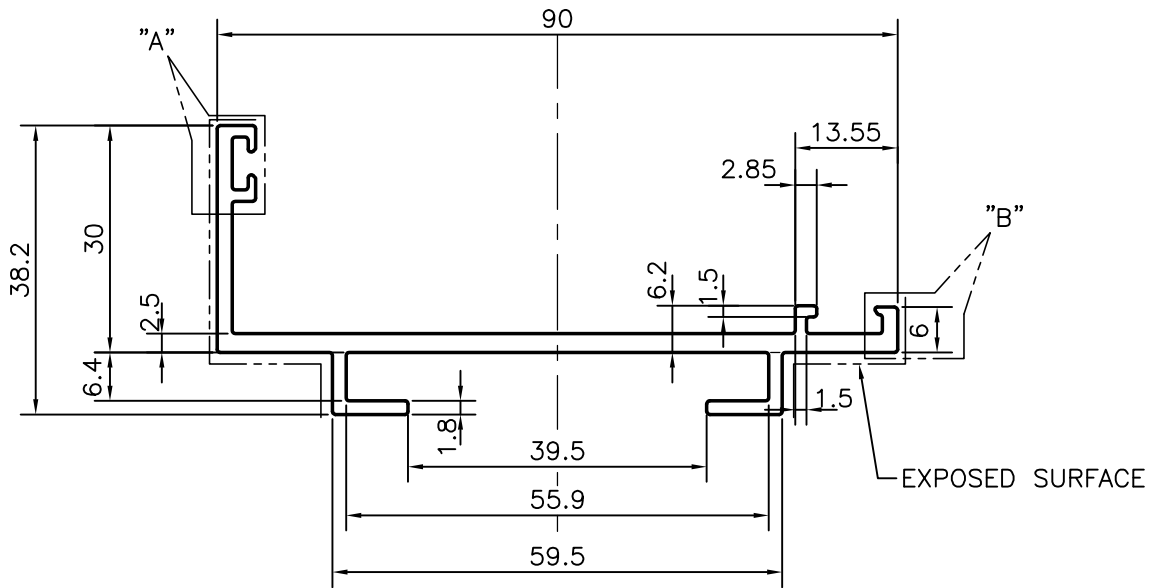

**PERMANENT EXCLUSIVE**



SYMBOL OF QUALITY  
AN ISO 9001 COMPANY

**JINDAL ALUMINIUM LTD.**  
BANGALORE-560073 (INDIA)

	NAME	DATE
DRAWN	J.P.KAUSHIK	28-08-2010
CHECKED		
APPROVED	S.S.GARG	10-09-2010
SCALE		1:1
AREA mm <sup>2</sup>		367.583
PERIMETER mm.		338.286
WEIGHT kg/m		0.992

1. ALL DIMENSIONS ARE IN mm.
2. ROUND OFF ALL SHARP CORNERS WITH 0.50 mm.
3. TOLERANCES WILL BE AS PER IS:3965-1981 UNLESS OTHERWISE SPECIFIED

PARTY'S NAME	ALUPRO BUILDING SYSTEMS.PVT.LTD.,BANGALORE
PARTY'S DRAWING No.	AS PER DRAWING
ALLOY & TEMPER	HE9 WP
DESCRIPTION	WINDOW TOP & VERTICAL SUB FRAME SECTION

DRAWING No.	SECTION No.
P-10340-1	-
X1354	X1354