

P-9769-1

S2462

X1366

KINDLY NOTE:-

TO CHECK WITH MATCHING PLASTIC PART

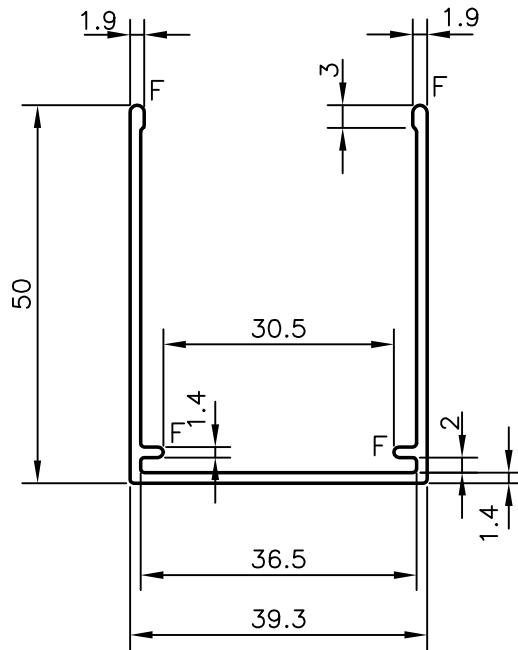

UNSPECIFIED RADII 0.5 mm

F = FULL RADIUS (4 PLACES )



SYMBOL OF QUALITY  
AN ISO 9001 COMPANY

**JINDAL ALUMINIUM LTD.**  
**BANGALORE-560073 (INDIA)**

	NAME	DATE
DRAWN	J.P.KAUSHIK	29-01-2010
CHECKED		
APPROVED	S.S.GARG	20-02-2010
SCALE		1:1
AREA mm <sup>2</sup>		201.586
PERIMETER mm.		284.613
WEIGHT kg/m		0.544
DRAWING No.	SECTION No.	
P-9769-1	-	
S2462	S2462	
X1366	X1366	

1. ALL DIMENSIONS ARE IN mm.
2. ROUND OFF ALL SHARP CORNERS WITH 0.50 mm.
3. TOLERANCES WILL BE AS PER IS:3965-1981, UNLESS OTHERWISE SPECIFIED

PARTY'S NAME	MATTS CORNER INDIA PVT. LTD., BANGALORE
PARTY'S DRAWING No.	AS PER DRAWING
ALLOY & TEMPER	HE9 WP
DESCRIPTION	BARRIER FREE TOP RAIL SECTION