

P-10426-1

X1369

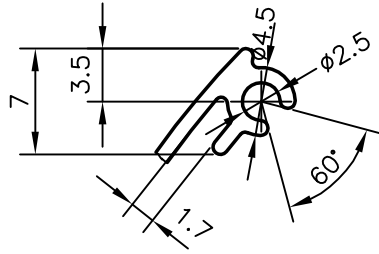

DETAIL OF "A"
SCALE 2:1

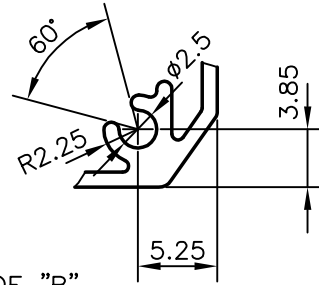

DETAIL OF "B"
SCALE 2:1

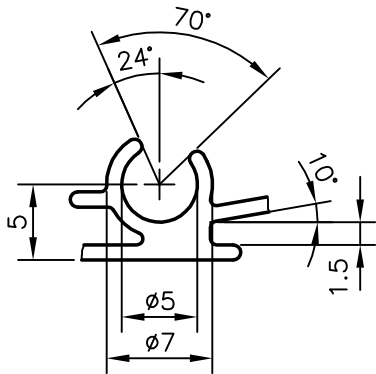
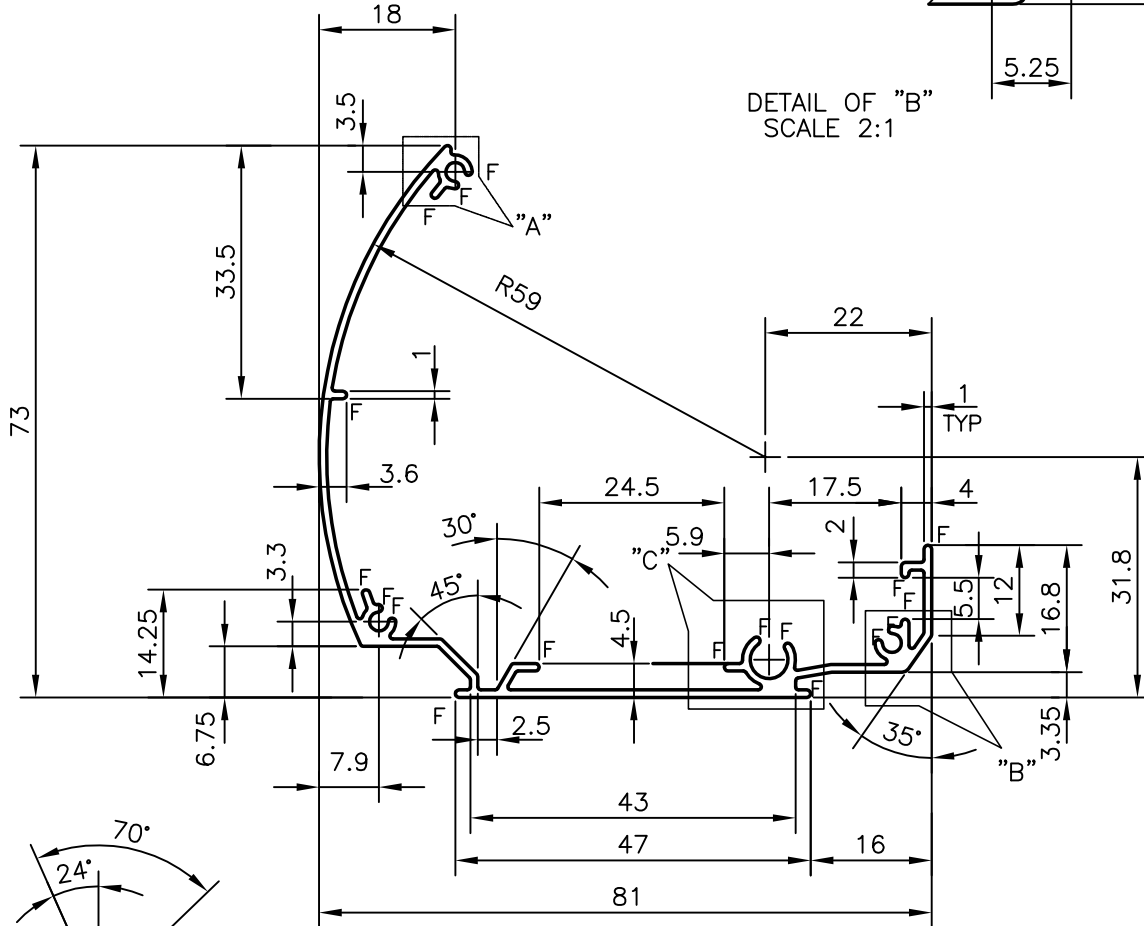

DETAIL OF "C"
SCALE 2:1

F = FULL RADIUS (18 PLACES)
UNSPECIFIED WALL THICKNESS 1.0 mm

PERMANENT EXCLUSIVE



SYMBOL OF QUALITY
AN ISO 9001 COMPANY

JINDAL ALUMINIUM LTD.
BANGALORE-560073 (INDIA)

	NAME	DATE
DRAWN	J.P.KAUSHIK	28-09-2010
CHECKED		
APPROVED	S.S.GARG	01-10-2010
SCALE		1:1
AREA mm ²		240.939
PERIMETER mm.		431.407
WEIGHT kg/m		0.651
DRAWING No.	SECTION No.	
P-10426-1	-	
X1369	X1369	

1. ALL DIMENSIONS ARE IN mm.
2. ROUND OFF ALL SHARP CORNERS WITH 0.40 mm.
3. TOLERANCES WILL BE AS PER IS:3965-1981 UNLESS OTHERWISE SPECIFIED

PARTY'S NAME	MATTS CORNER INDIA PVT. LTD., BANGALORE
PARTY'S DRAWING No.	AS PER SAMPLE
ALLOY & TEMPER	HE9 WP
DESCRIPTION	MISC. SECTION