

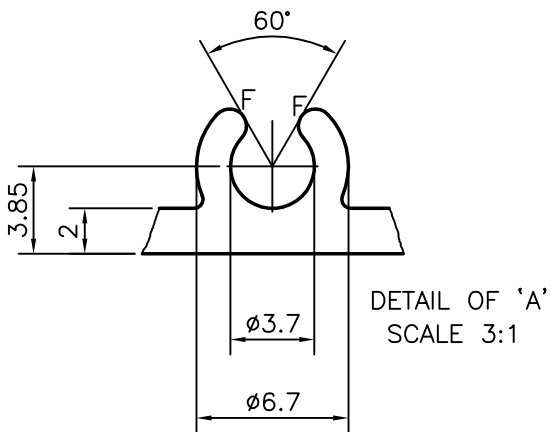

P-10406-1

X1376

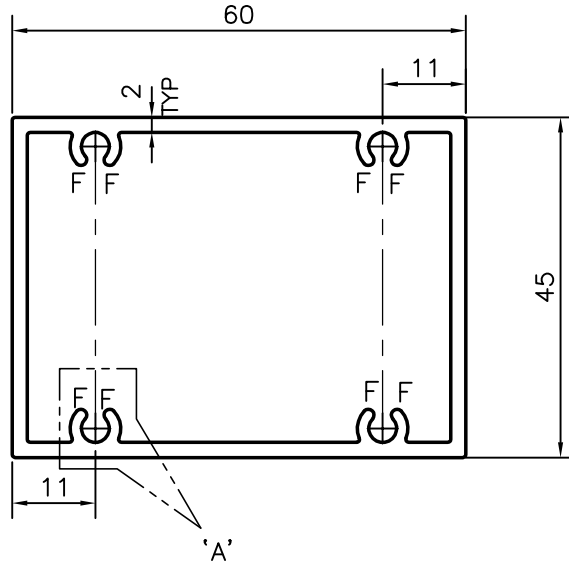

F = FULL RADIUS (8 PLACES)

PERMANENT EXCLUSIVE

 SYMBOL OF QUALITY AN ISO 9001 COMPANY	JINDAL ALUMINIUM LTD. BANGALORE-560073 (INDIA)		NAME	DATE
		DRAWN	J.P.KAUSHIK	01-10-2010
1. ALL DIMENSIONS ARE IN mm. 2. ROUND OFF ALL SHARP CORNERS WITH 0.40 mm. 3. TOLERANCES WILL BE AS PER IS:6477-1983 UNLESS OTHERWISE SPECIFIED		CHECKED		
		APPROVED	S.S.GARG	08-10-2010
PARTY'S NAME ALUPRO BUILDING SYSTEMS.PVT.LTD.,BANGALORE		SCALE		1:1
		AREA mm ²		460.795
PARTY'S DRAWING No. ABS 1H-SS-005		PERIMETER mm.		209.313
		WEIGHT kg/m		1.244
ALLOY & TEMPER HE9 WP		DRAWING No.		SECTION No.
		P-10406-1		-
DESCRIPTION WINDOW SECTION		X1376		X1376