

P-10471

X1377

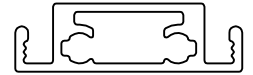

DETAIL OF "A"
SCALE 5:1

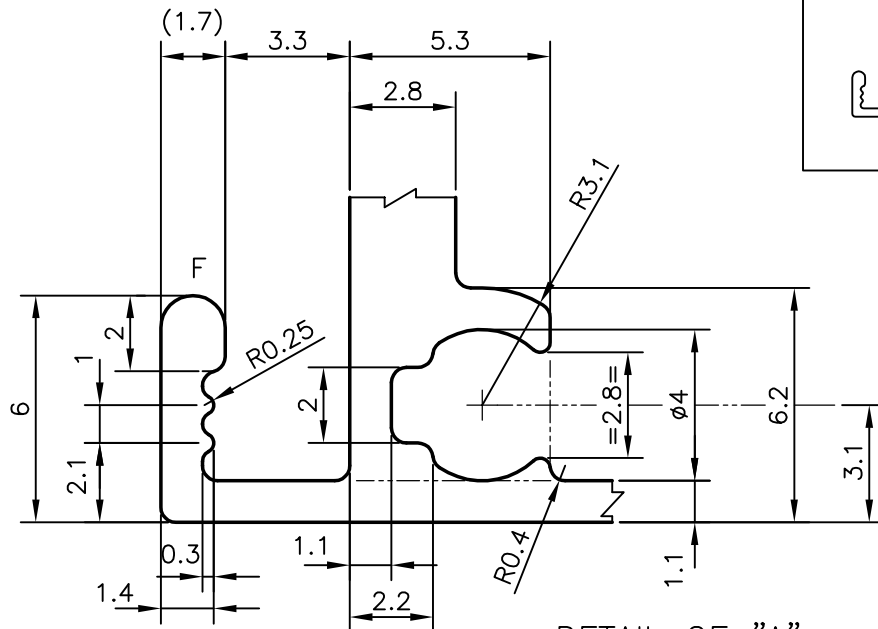
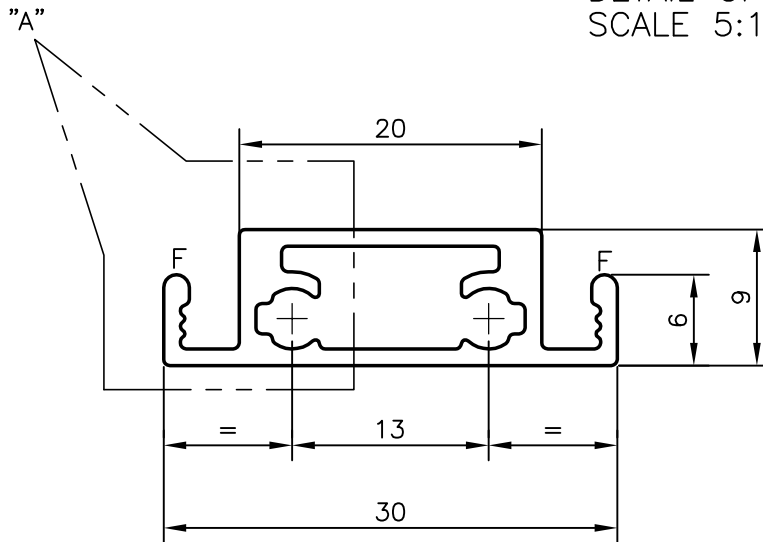

F = FULL RADIUS

GENERAL WALL THICKNESS 1.10 mm

PERMANENT EXCLUSIVE

 SYMBOL OF QUALITY AN ISO 9001 COMPANY	JINDAL ALUMINIUM LTD. BANGALORE-560073 (INDIA)	NAME	DATE
		DRAWN	J.P.KAUSHIK 07-10-2010
		CHECKED	
		APPROVED	S.S.GARG 14-10-2010
1. ALL DIMENSIONS ARE IN mm. 2. ROUND OFF ALL SHARP CORNERS WITH 0.40 mm. 3. TOLERANCES WILL BE AS PER IS:6477-1983 UNLESS OTHERWISE SPECIFIED		SCALE	2:1
		AREA mm ²	104.737
		PERIMETER mm.	97.443
PARTY'S NAME	KARTHIK INDUSTRIES, BANGALORE	WEIGHT kg/m	0.283
PARTY'S DRAWING No.	AS PER DRAWING	DRAWING No.	SECTION No.
ALLOY & TEMPER	HE9 WP	P-10471	-
DESCRIPTION	FLY SCREEN SECTION	X1377	X1377