

P-10419-1

X1382

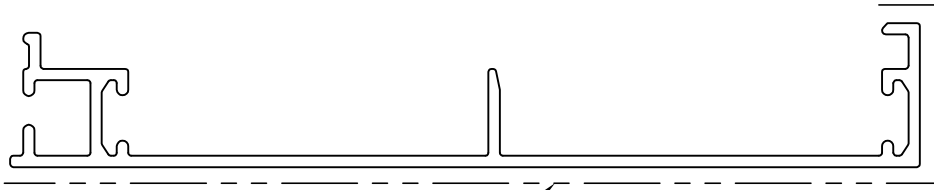

EXPOSED SURFACE

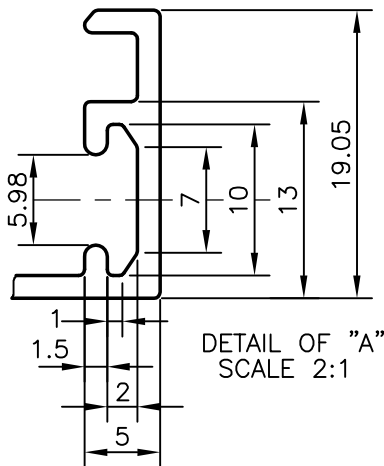
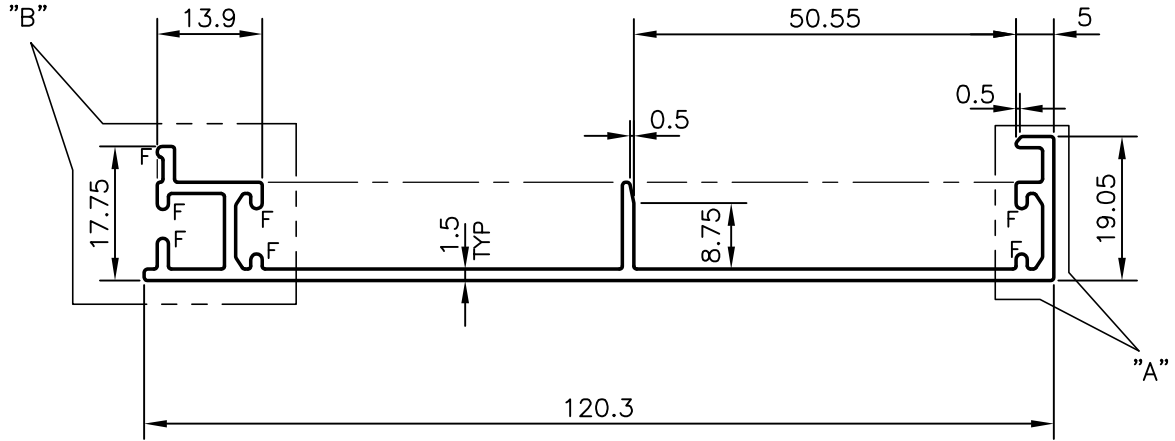

DETAIL OF "A"
SCALE 2:1

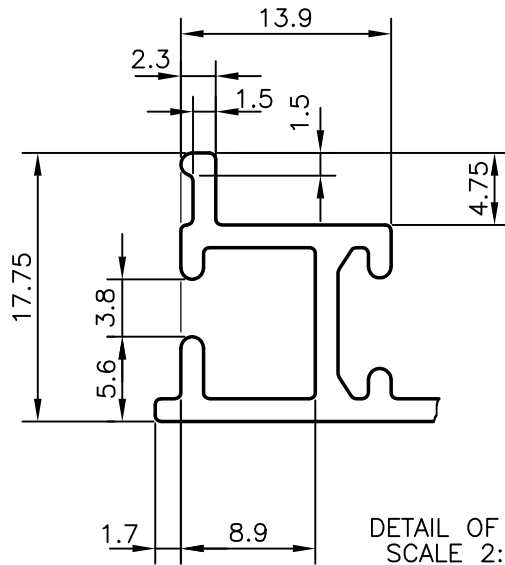

DETAIL OF "B"
SCALE 2:1

F = FULL RADIUS (7 PLACES)



SYMBOL OF QUALITY
AN ISO 9001 COMPANY

JINDAL ALUMINIUM LTD.
BANGALORE-560073 (INDIA)

	NAME	DATE
DRAWN	J.P.KAUSHIK	01-10-2010
CHECKED		
APPROVED	S.S.GARG	15-10-2010
SCALE		1:1
AREA mm ²		300.534
PERIMETER mm.		389.711
WEIGHT kg/m		0.811
DRAWING No.	SECTION No.	
P-10419-1	-	
X1382	X1382	

1. ALL DIMENSIONS ARE IN mm.
2. ROUND OFF ALL SHARP CORNERS WITH 0.40 mm.
3. TOLERANCES WILL BE AS PER BS:EN-755 UNLESS OTHERWISE SPECIFIED

PARTY'S NAME	LYNCH METAL, USA
PARTY'S DRAWING No.	PAV-0306
ALLOY & TEMPER	6063 T5
DESCRIPTION	MISC. SECTION