

P-10440

X1393

EXPOSED SURFACE →

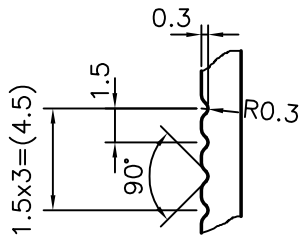

DETAIL OF "B"
SCALE 3:1

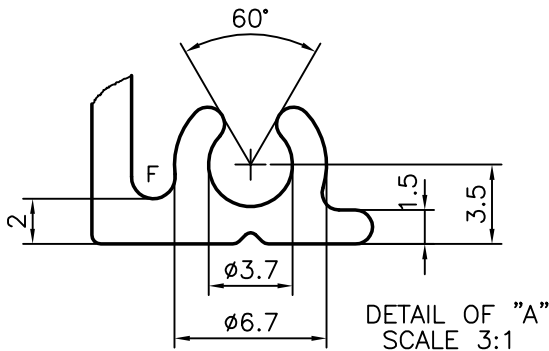
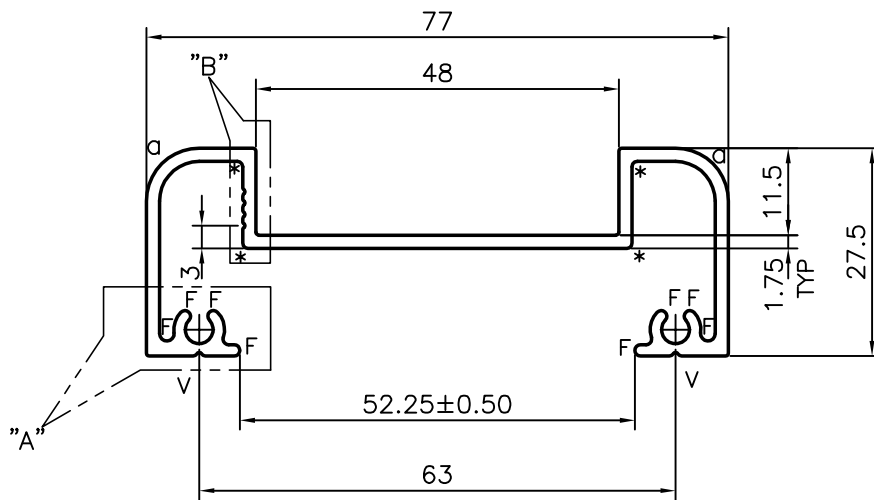
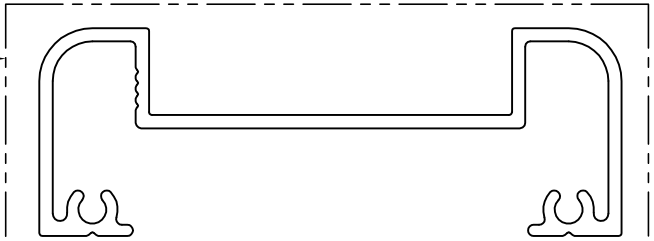

DETAIL OF "A"
SCALE 3:1

- a = 7 RADIUS (2 PLACES)
- * = 0.7 RADIUS (4 PLACES)
- F = FULL RADIUS (4 PLACES)
- V = V GROOVE 0.5x90° (2 PLACES)



SYMBOL OF QUALITY
AN ISO 9001 COMPANY

JINDAL ALUMINIUM LTD.
BANGALORE-560073 (INDIA)

	NAME	DATE
DRAWN	J.P.KAUSHIK	30-09-2010
CHECKED		
APPROVED	S.S.GARG	21-10-2010
SCALE		1:1
AREA mm ²		319.557
PERIMETER mm.		363.967
WEIGHT kg/m		0.863
DRAWING No.	SECTION No.	
P-10440		
X1393	X1393	

1. ALL DIMENSIONS ARE IN mm.
2. ROUND OFF ALL SHARP CORNERS WITH 0.40 mm.
3. TOLERANCES WILL BE AS PER BS:EN-755 UNLESS OTHERWISE SPECIFIED

PARTY'S NAME	KOMFORT OFFICE ENVIRONMENTS PLC., U.K.
PARTY'S DRAWING No.	TF322
ALLOY & TEMPER	6063 T6
DESCRIPTION	GLAZING PROFILE