

P-10420-1

X1397

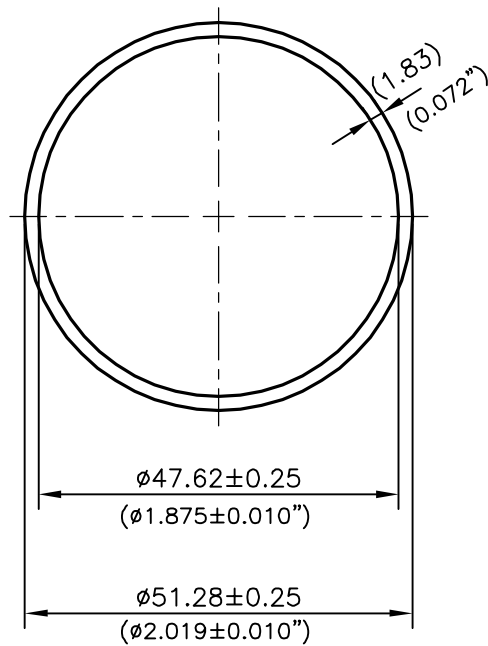

STRAIGHTNESS :- 2.08 mm/ M
 ECCENTRICITY :- $\pm 10\%$ OF WALL THICKNESS

NOTE :-

SUPPLIED WEIGHT SHOULD BE NOT MORE THAN +7% OF DRAWING WEIGHT

 SYMBOL OF QUALITY AN ISO 9001 COMPANY	JINDAL ALUMINIUM LTD. BANGALORE-560073 (INDIA)	NAME	DATE
		DRAWN	J.P.KAUSHIK
		CHECKED	
		APPROVED	S.S.GARG
		SCALE	1:1
		AREA mm ²	284.294
		PERIMETER mm.	161.101
		WEIGHT kg/m	0.768
PARTY'S NAME	ON THE HOOK,USA	DRAWING No.	SECTION No.
PARTY'S DRAWING No.	AS PERDRAWING	P-10420-1	-
ALLOY & TEMPER	6063 T6	X1397	X1397
DESCRIPTION	ROUND TUBE		