

P-10520-1

X1401

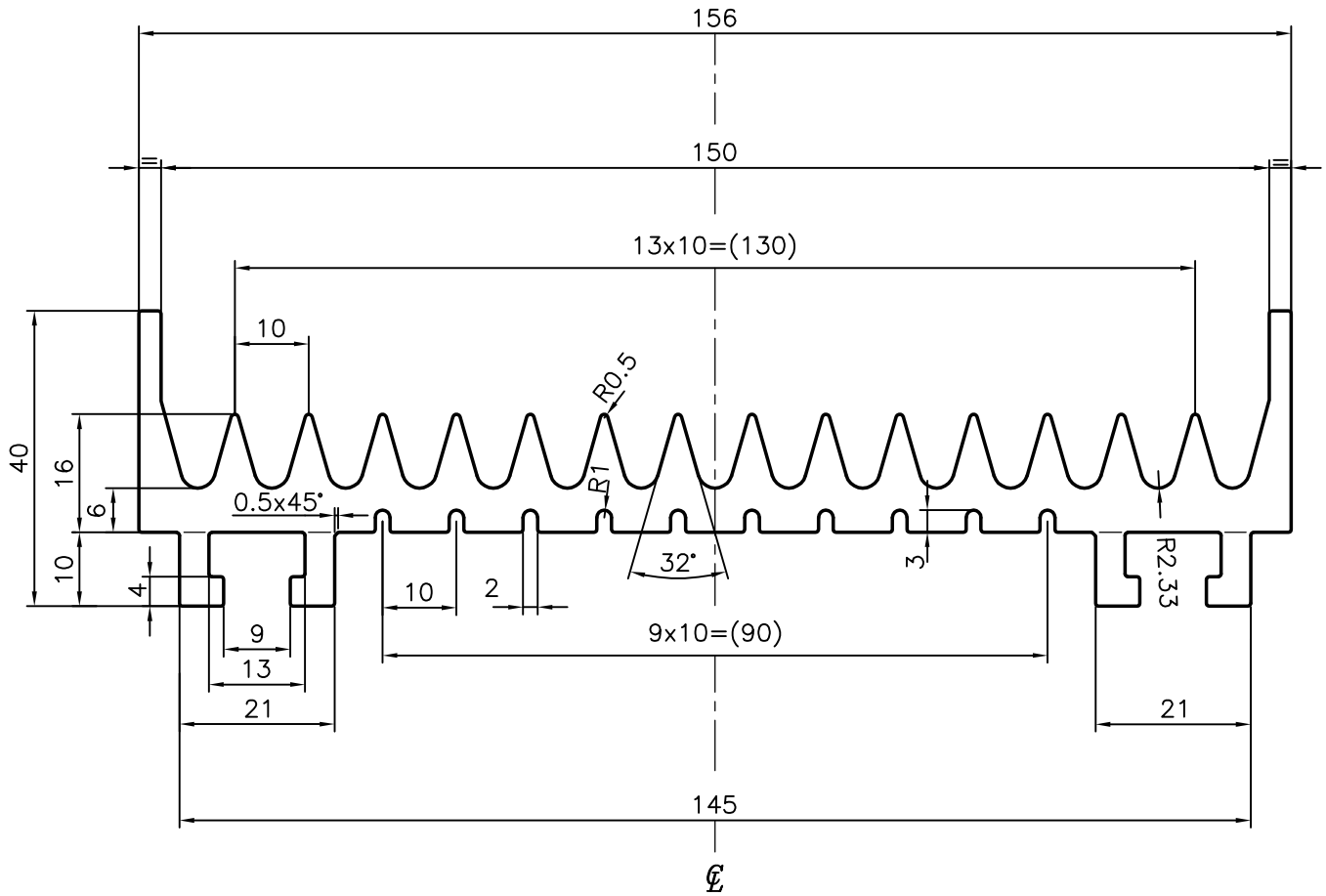

SYMBOL OF QUALITY
AN ISO 9001 COMPANY

JINDAL ALUMINIUM LTD.
BANGALORE-560073 (INDIA)

	NAME	DATE
DRAWN	J.P.KAUSHIK	26-10-2010
CHECKED		
APPROVED	S.S.GARG	28-10-2010
SCALE		1:1
AREA mm ²		1777.473
PERIMETER mm.		745.882
WEIGHT kg/m		4.799
DRAWING No.	SECTION No.	
P-10520-1	-	
X1401	X1401	

1. ALL DIMENSIONS ARE IN mm.
2. ROUND OFF ALL SHARP CORNERS WITH 0.40 mm.
3. TOLERANCES WILL BE AS PER IS:3965-1981 UNLESS OTHERWISE SPECIFIED

PARTY'S NAME	CHROMO SORTEX TECHNOLOGIES PVT. LTD., BANGALORE
PARTY'S DRAWING No.	CS120-502-P01
ALLOY & TEMPER	HE9 WP
DESCRIPTION	CHUTE SECTION