

P-4387
4927
22879
X1408

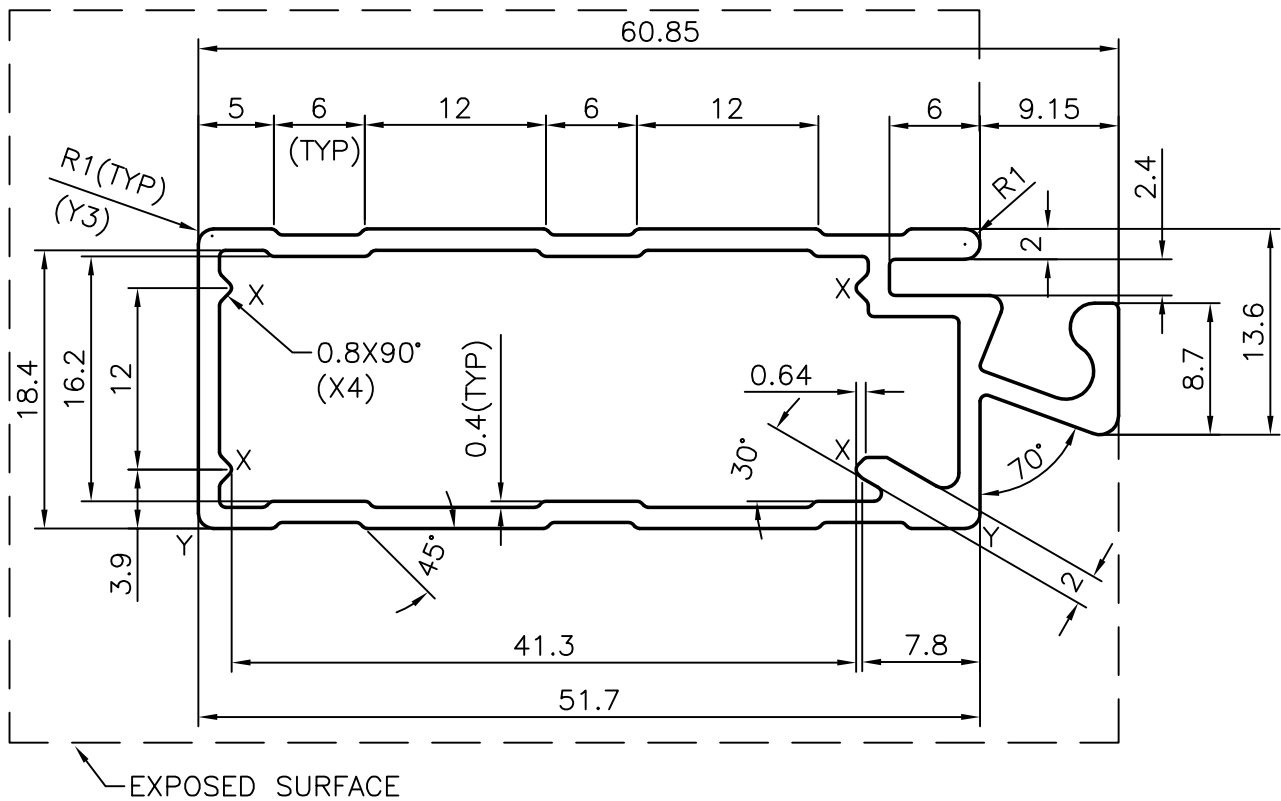

GENERAL WALL THICKNESS 1.4±0.18

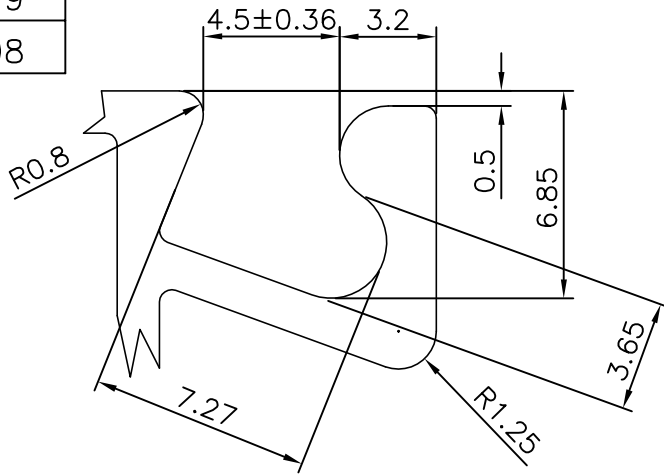
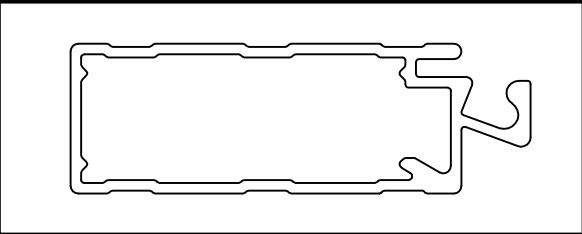

SYMBOL OF QUALITY
AN ISO 9001 COMPANY

JINDAL ALUMINIUM LTD.
BANGALORE-560073 (INDIA)

		NAME	DATE
DRAWN		PANDAGRE	14.08.2003
CHECKED			
APPROVED			
SCALE		1:1	
AREA mm ²		255.17	
PERIMETER mm.		187.61	
WEIGHT kg/m		0.688	
DRAWING No.		SECTION No.	
P-4387		-	
4927		4927	
22879		22879	
X1408		X1408	

1. ALL DIMENSIONS ARE IN mm.
2. ROUND OFF ALL SHARP CORNERS WITH 0.40 mm.
3. TOLERANCES WILL BE AS PER IS: 6477-1983 UNLESS OTHERWISE SPECIFIED

PARTY'S NAME	PROSOURCE INDUSTRIAL SOLUTIONS INC. CANADA
PARTY'S DRAWING No.	A3185
ALLOY & TEMPER	HE9 WP
DESCRIPTION	DOOR SASH