

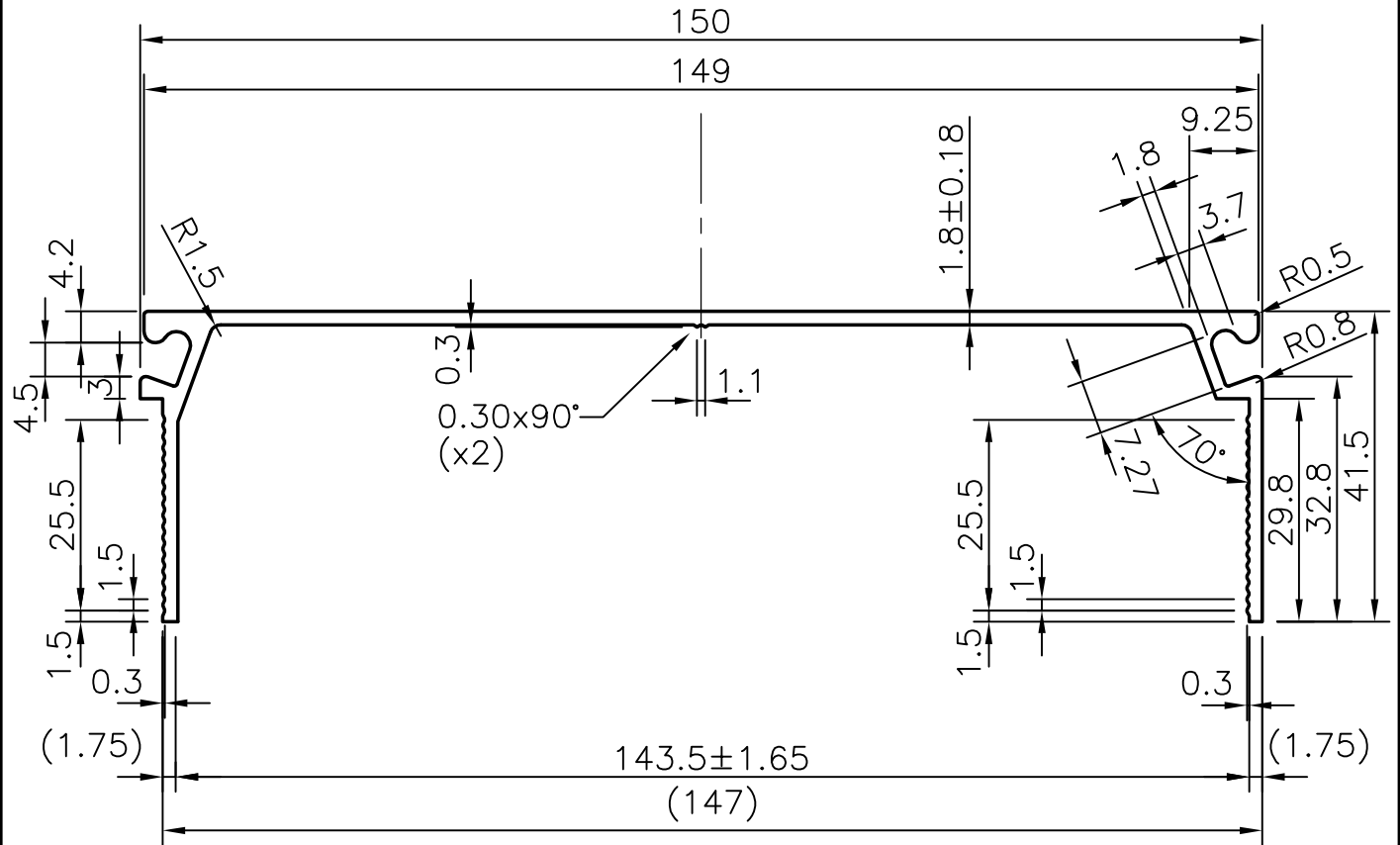

P-4231
4924
22878
X1410



 SYMBOL OF QUALITY AN ISO 9002 COMPANY	JINDAL ALUMINIUM LTD. BANGALORE-560073 (INDIA)	DRAWN	NAME	DATE
		CHECKED	R.D.Sharma	10-05-2003
1. ALL DIMENSIONS ARE IN mm. 2. ROUND OFF ALL SHARP CORNERS WITH 0.40 mm. 3. TOLERANCES WILL BE AS PER COMMERCIAL, UNLESS OTHERWISE SPECIFIED		APPROVED		
		SCALE		1:1
PARTY'S NAME PROSOURCE INDUSTRIAL SOLUTIONS INC.		AREA	mm ²	467
		PERIMETER	mm.	484.8
PARTY'S DRAWING No. AS PER DRAWING		WEIGHT	kg/m	1.261
		DRAWING No.	SECTION No.	
ALLOY & TEMPER 6063 T54		P-4231	-	
		4924	4924	
DESCRIPTION SUNCOAST CHANNEL		22878	22878	
		X1410	X1410	