

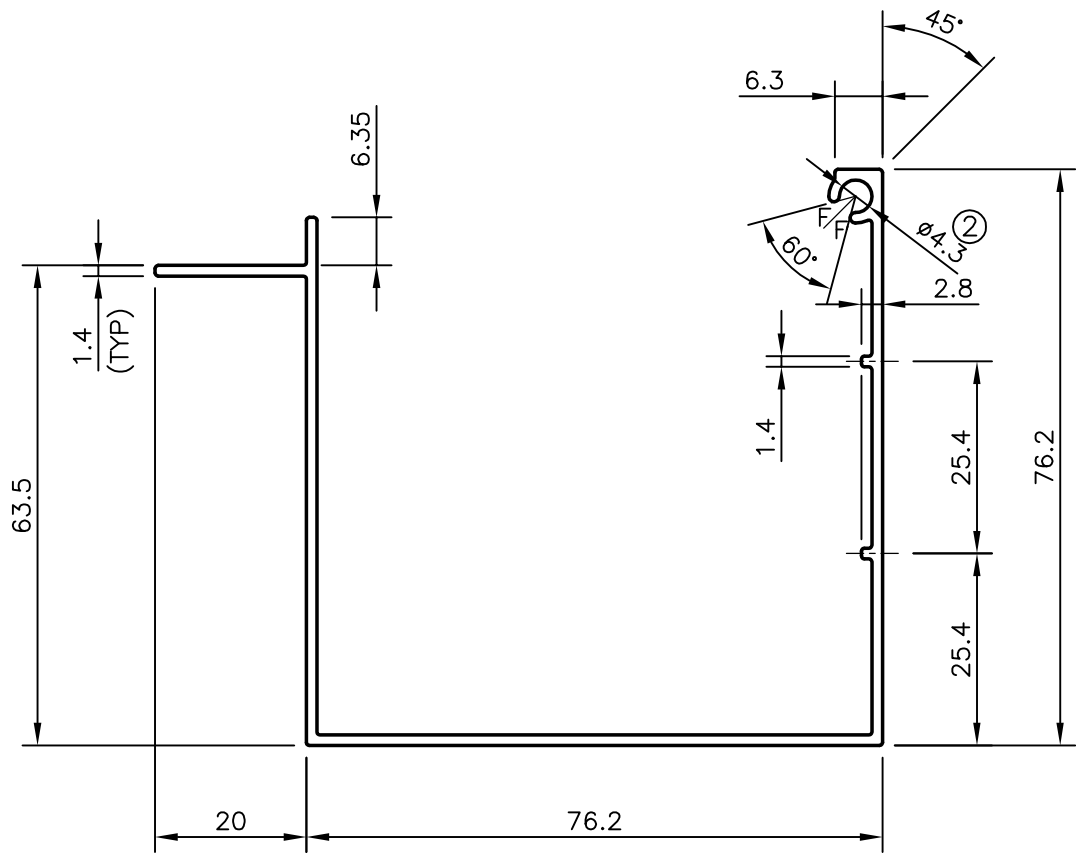

P-9651-1
 29380
 X1413



ISSUE: -2

② SCREW BOX ϕ CHANGED FROM $\phi 3.0$ TO $\phi 4.3$ & WEIGHT ALSO CHANGED FROM 0.952 kg/m TO 0.960 kg/m

GENERAL WALL THICKNESS 1.4 mm

 SYMBOL OF QUALITY AN ISO 9001 COMPANY	JINDAL ALUMINIUM LTD. BANGALORE-560073 (INDIA)	NAME	DATE
		DRAWN	J.P.KAUSHIK 24-04-2010
1. ALL DIMENSIONS ARE IN mm. 2. ROUND OFF ALL SHARP CORNERS WITH 0.40 mm. 3. TOLERANCES WILL BE AS PER BS:EN-755 UNLESS OTHERWISE SPECIFIED		CHECKED	
		APPROVED	S.S.GARG 30-04-2010
PARTY'S NAME PROSOURCE INDUSTRIAL SOLUTIONS ALBERTA, CANADA		SCALE	1:1
		AREA mm ²	355.638
PARTY'S DRAWING No. AS PER SKETCK (OUR SECTION NO. 28954)		PERIMETER mm.	554.027
		WEIGHT kg/m	0.960
ALLOY & TEMPER 6060 T5		DRAWING No.	SECTION No.
		P-9651-1	-
DESCRIPTION MISC. SECTION		29380	29380(ISSUE-2)
		X1413	X1413