

P-10547-1

X1425

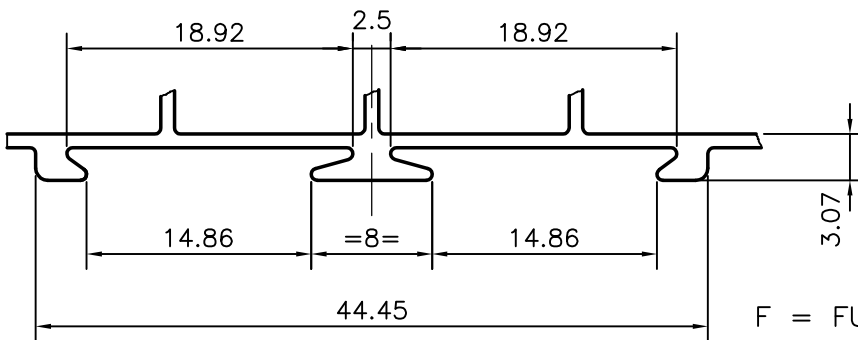
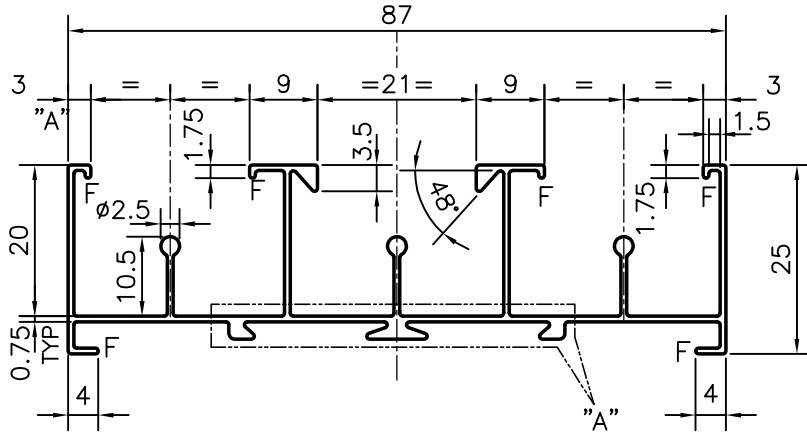
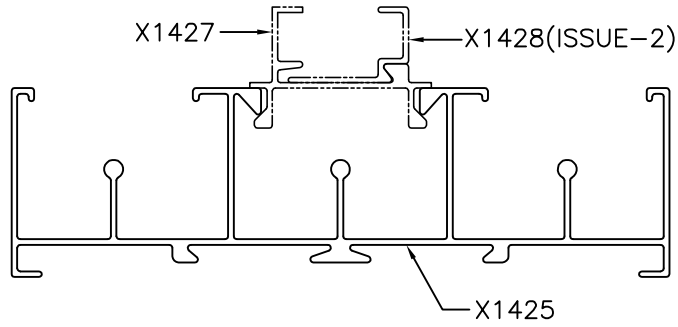

F = FULL RADIUS (6 PLACES)

DETAIL OF "A"
SCALE 2:1

PERMANENT EXCLUSIVE



SYMBOL OF QUALITY
AN ISO 9001 COMPANY

JINDAL ALUMINIUM LTD.
BANGALORE-560073 (INDIA)

	NAME	DATE
DRAWN	J.P.KAUSHIK	17-11-2010
CHECKED		
APPROVED	S.S.GARG	20-11-2010
SCALE		1:1
AREA mm ²		222.802
PERIMETER mm.		506.154
WEIGHT kg/m		0.602
DRAWING No.	SECTION No.	
P-10547-1	-	
X1425	X1425	

1. ALL DIMENSIONS ARE IN mm.
2. ROUND OFF ALL SHARP CORNERS WITH 0.40 mm.
3. TOLERANCES WILL BE AS PER IS:3965-1981 UNLESS OTHERWISE SPECIFIED

PARTY'S NAME	ASHWANI & SONS, GHAZIABAD
PARTY'S DRAWING No.	AS PER DRAWING
ALLOY & TEMPER	HE9 WP
DESCRIPTION	WINDOW SECTION (BOTTOM)