

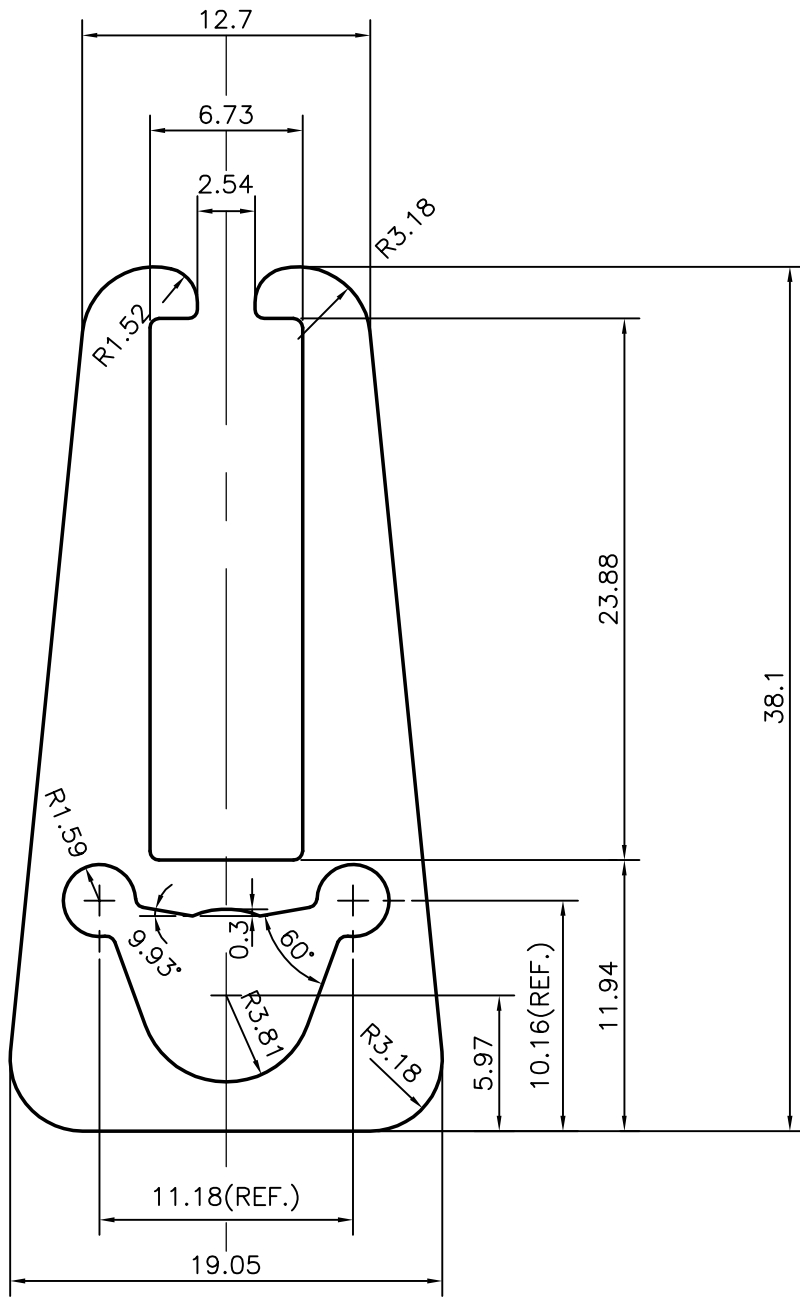

P-10662
X1449

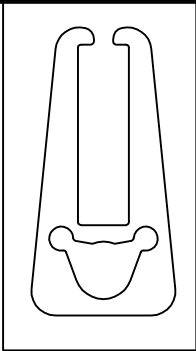

PLEASE CONFIRM ALL THE DIMENSIONS AND MATCH WITH YOUR MATCHING COMPONENT

PLEASE SPECIFY THE EXPOSED SURFACE IN THE DRAWING WHEREVER BETTER FINISH REQUIRED.

 SYMBOL OF QUALITY AN ISO 9001 COMPANY	JINDAL ALUMINIUM LTD. BANGALORE-560073 (INDIA)	NAME		DATE
		DRAWN	J.P.KAUSHIK	18-12-2010
		CHECKED		
		APPROVED		S.S.GARG
		SCALE		3:1
		AREA mm ²		357.008
		PERIMETER mm.		161.091
		WEIGHT kg/m		0.964
PARTY'S NAME	DA-LITE SCREEN COMPANY,INC USA.	DRAWING No.		SECTION No.
PARTY'S DRAWING No.	90983	P-10662		-
ALLOY & TEMPER	6063 T6	X1449		X1449
DESCRIPTION	MISC. SECTION			