

P-10663

X1450

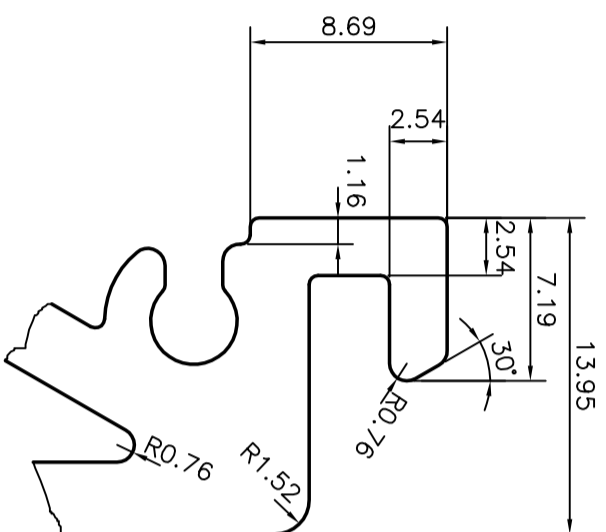

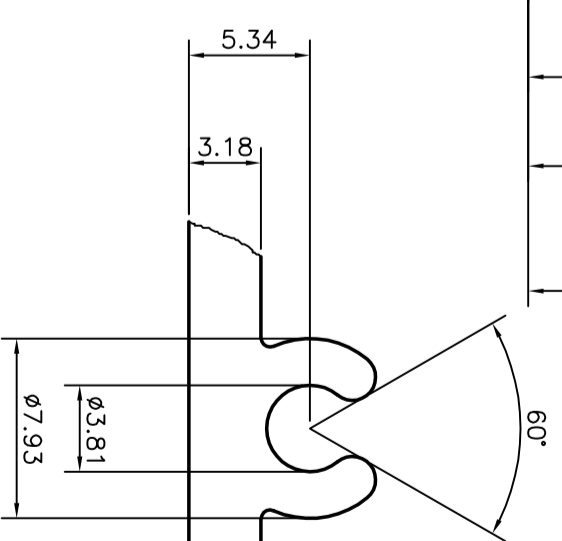
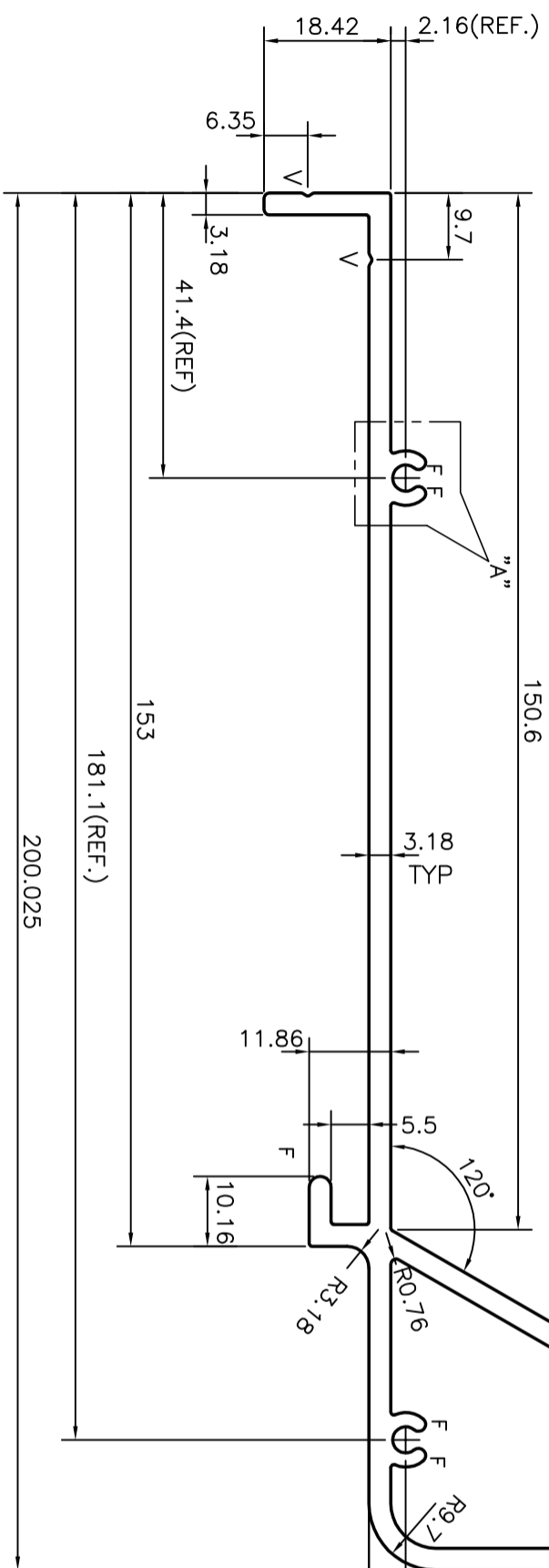

DETAIL OF "B"
SCALE 3:1

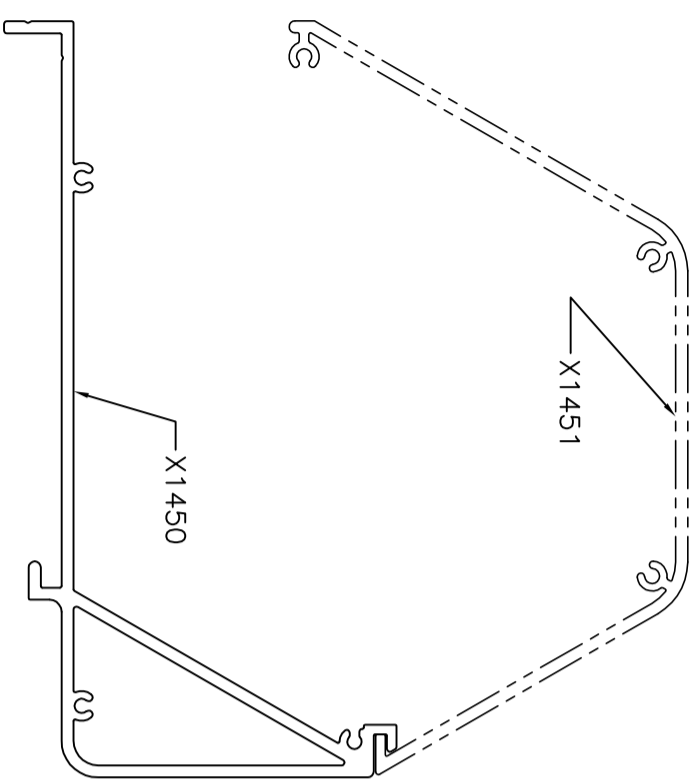

DETAIL OF "A"
SCALE 3:1

V = V GROOVE 0.45x120° (2 PLACES)
F = FULL RADIUS (5 PLACES)



 SYMBOL OF QUALITY AN ISO 9001 COMPANY		JINDAL ALUMINIUM LTD. BANGALORE-560073 (INDIA)		DRAWN J.P. KAUSHIK 20-12-2010
1. ALL DIMENSIONS ARE IN mm. 2. ROUND OFF ALL SHARP CORNERS WITH 0.40 mm. 3. TOLERANCES WILL BE AS PER BS:EN-755 UNLESS OTHERWISE SPECIFIED		APPROVED S.S. GARG 28-12-2010	SCALE 1:1	CHECKED
PARTY'S NAME DA-LITE SCREEN COMPANY, INC USA.	PARTY'S DRAWING No. 96309	AREA mm ² 1374.791	PERIMETER mm. 643.678	WEIGHT kg/m 3.712
ALLOY & TEMPER 6063 T6	DESCRIPTION MISC. SECTION	DRAWING No. P-10663 X1450	SECTION No. - X1450	