

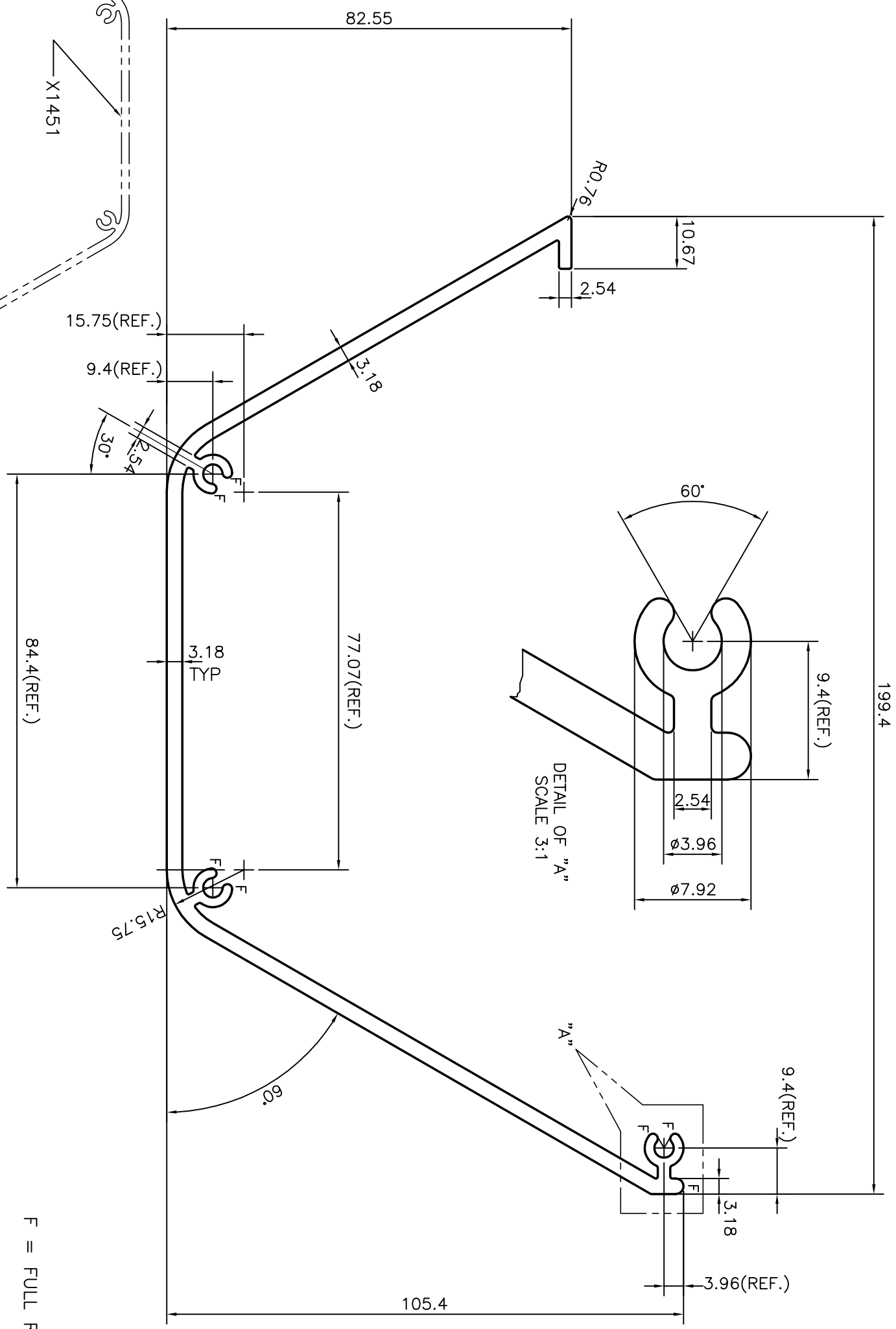

P-10664

X1451

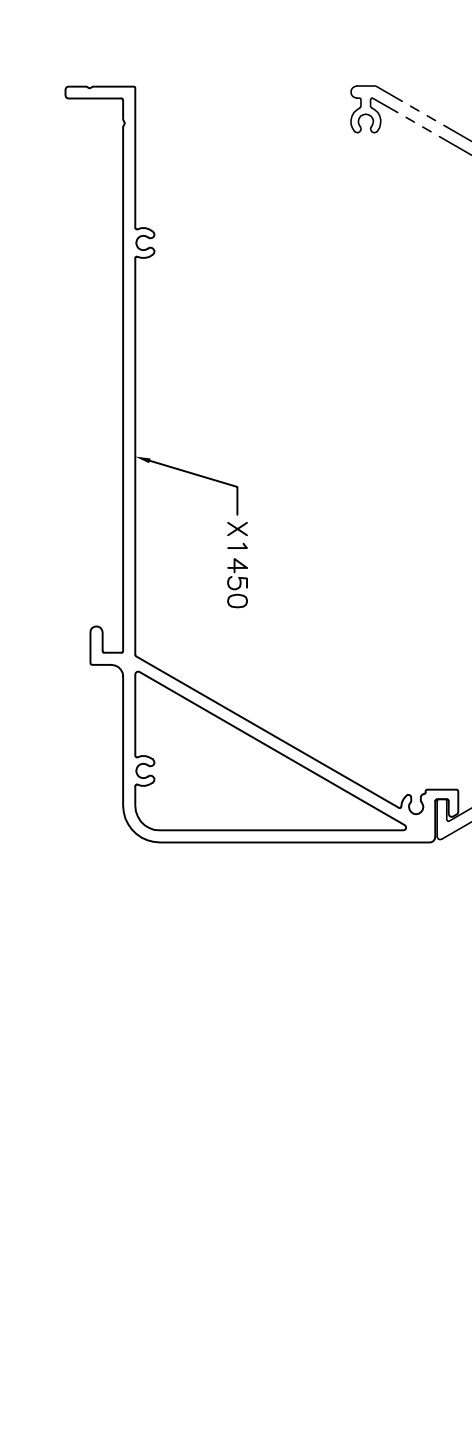

F = FULL RADIUS (7 PLACES)



 SYMBOL OF QUALITY AN ISO 9001 COMPANY		JINDAL ALUMINIUM LTD. BANGALORE-560073 (INDIA)		DRAWN J.P. KAUSHIK 20-12-2010
1. ALL DIMENSIONS ARE IN mm. 2. ROUND OFF ALL SHARP CORNERS WITH 0.40 mm. 3. TOLERANCES WILL BE AS PER BS:EN-755 UNLESS OTHERWISE SPECIFIED		CHECKED APPROVED S.S. GARG 28-12-2010	SCALE 1:1	DATE
PARTY'S NAME DA-LITE SCREEN COMPANY, INC USA.	PARTY'S DRAWING No. 96307	AREA mm ² 1081.31	PERIMETER mm. 715.785	WEIGHT kg/m 2.92
ALLOY & TEMPER 6063 T6	MISC. SECTION	DRAWING No. P-10664 X1451	SECTION No. - X1451	
DESCRIPTION				