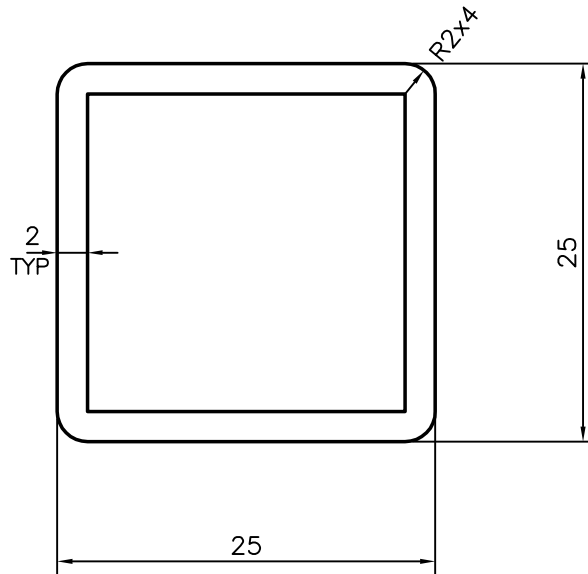

P-10622

X1455

1:1

**PERMANENT EXCLUSIVE**

TOLERANCES ON OVERALL WIDTHS & WIDTHS ACROSS FLATS OF BARS, & REGULAR SECTIONS

UPTO 6.40mm - ± 0.20	UPTO 32.0mm - ± 0.38	UPTO 120.0mm - ± 0.85	UPTO 320.00mm - ± 1.70
UPTO 10.0mm - ± 0.23	UPTO 50.0mm - ± 0.46	UPTO 160.0mm - ± 1.02	
UPTO 12.0mm - ± 0.25	UPTO 60.0mm - ± 0.53	UPTO 200.0mm - ± 1.14	
UPTO 16.0mm - ± 0.28	UPTO 80.0mm - ± 0.69	UPTO 250.0mm - ± 1.40	
UPTO 25.0mm - ± 0.30	UPTO 100.0mm - ± 0.75	UPTO 300.0mm - ± 1.65	



SYMBOL OF QUALITY
AN ISO 9001 COMPANY

JINDAL ALUMINIUM LTD.
BANGALORE-560073 (INDIA)

	NAME	DATE
DRAWN	J.P.KAUSHIK	04-12-2010
CHECKED		
APPROVED	S.S.GARG	05-01-2011

- ALL DIMENSIONS ARE IN mm.
- ROUND OFF ALL SHARP CORNERS WITH 0.40 mm.
- TOLERANCES WILL BE AS PER,IS:6477-1983 UNLESS OTHERWISE SPECIFIED

SCALE	2:1
AREA mm ²	180.566
PERIMETER mm.	96.566
WEIGHT kg/m	0.488

PARTY'S NAME	VOLVO BUSES INDIA PVT. LTD., BANGALORE	DRAWING No.	P-10622	SECTION No.	-
PARTY'S DRAWING No.	21548781		X1455		X1455
ALLOY & TEMPER	63400 W				
DESCRIPTION	SQUARE TUBE				