

P-10693-1

X1467

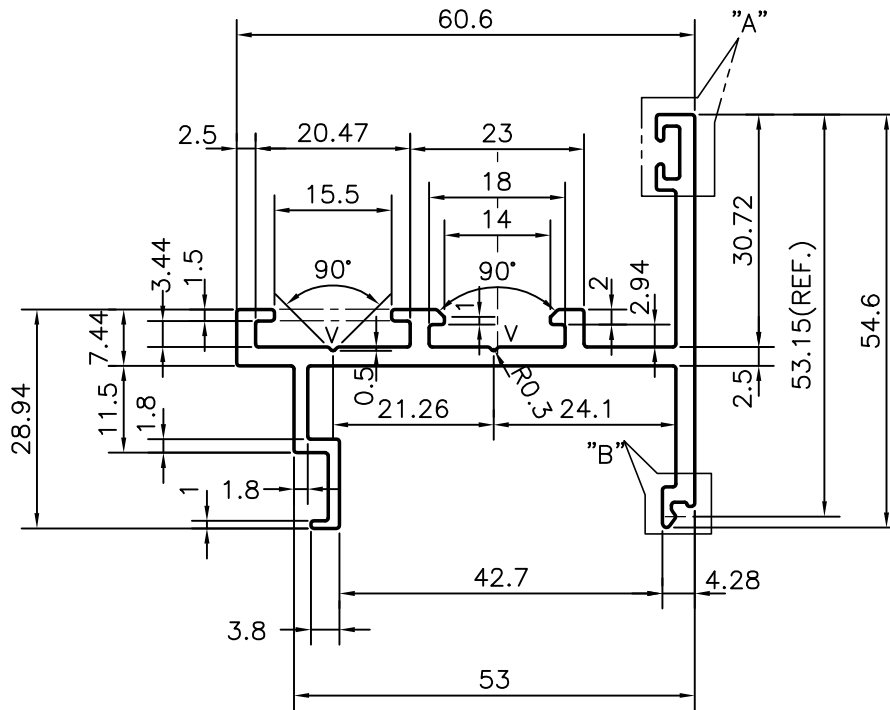
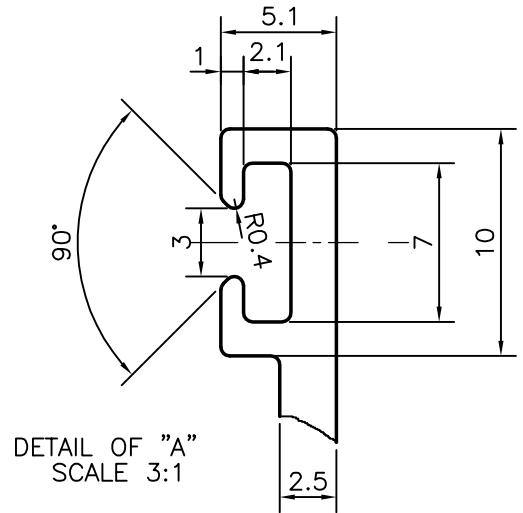
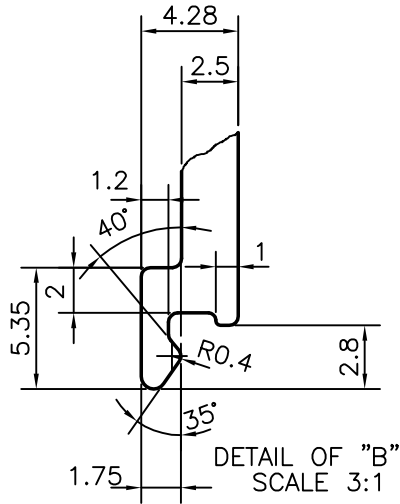

V = V GROOVE 0.5x90° (2 PLACES)

PERMANENT EXCLUSIVE



SYMBOL OF QUALITY
AN ISO 9001 COMPANY

JINDAL ALUMINIUM LTD.
BANGALORE-560073 (INDIA)

	NAME	DATE
DRAWN	J.P.KAUSHIK	11-01-2011
CHECKED		
APPROVED	S.S.GARG	17-01-2011
SCALE		1:1
AREA mm ²		386.389
PERIMETER mm.		349.043
WEIGHT kg/m		1.043

1. ALL DIMENSIONS ARE IN mm.
2. ROUND OFF ALL SHARP CORNERS WITH 0.40 mm.
3. TOLERANCES WILL BE AS PER IS:3965-1981 UNLESS OTHERWISE SPECIFIED

PARTY'S NAME	ALUPRO BUILDING SYSTEMS.PVT.LTD.,BANGALORE	DRAWING No.	P-10693-1	SECTION No.	-
PARTY'S DRAWING No.	AS PER DRAWING		X1467		X1467
ALLOY & TEMPER	HE9 WP				
DESCRIPTION	WINDOW SECTION				