

P-10769

X1476

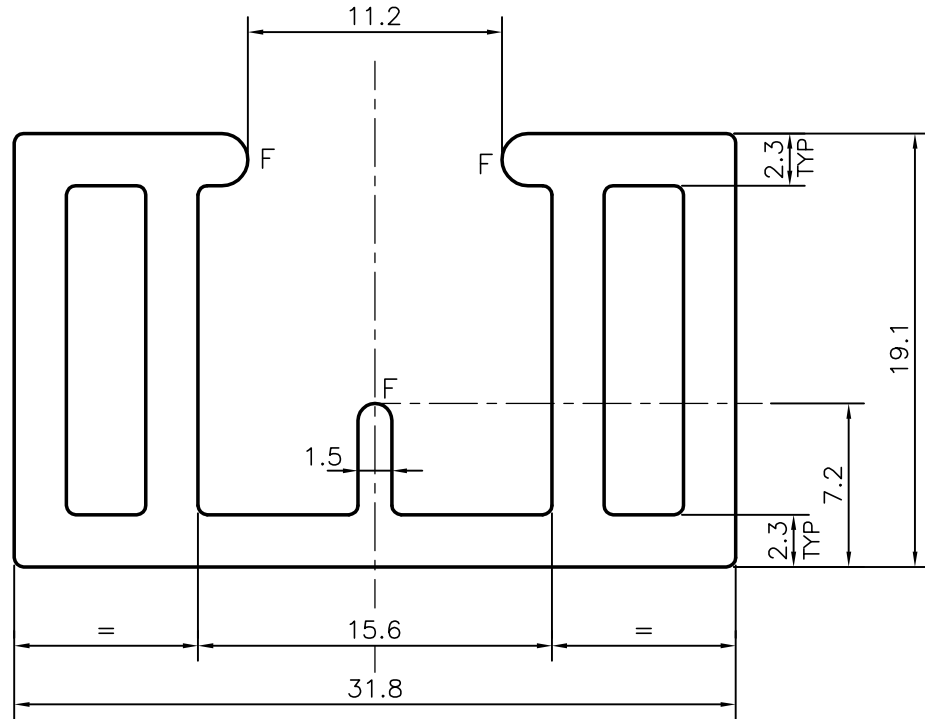

F = FULL RADIUS (3 PLACES)

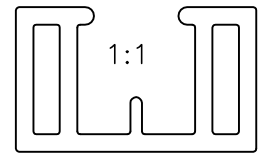

SYMBOL OF QUALITY
AN ISO 9001 COMPANY

JINDAL ALUMINIUM LTD.
BANGALORE-560073 (INDIA)

	NAME	DATE
DRAWN	J.P.KAUSHIK	11-02-2011
CHECKED		
APPROVED	J.N. RAI	16-02-2011
SCALE		3:1
AREA mm ²		260.237
PERIMETER mm.		149.665
WEIGHT kg/m		0.703
DRAWING No.	SECTION No.	
P-10769	-	
X1476	X1476	

1. ALL DIMENSIONS ARE IN mm.
2. ROUND OFF ALL SHARP CORNERS WITH 0.40 mm.
3. TOLERANCES WILL BE AS PER, BS:EN-755-9 UNLESS OTHERWISE SPECIFIED

PARTY'S NAME	PROSOURCE INDL. SOLUTIONS, CANADA
PARTY'S DRAWING No.	AS PER DRAWING
ALLOY & TEMPER	6063 T5
DESCRIPTION	BOTTOM GLASS CHANNEL