

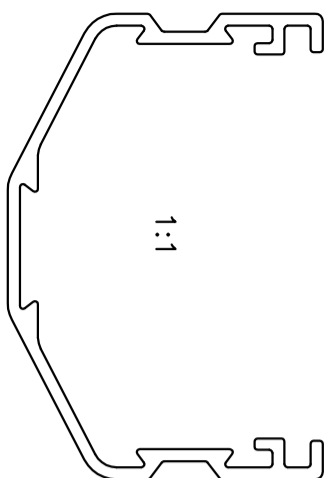

P-11020

X1521

ISSUE:-2 DIMENSIONS CHANGED
 ISSUE:-3 TOLERANCE CHANGED ON FOLLOWING DIMENSIONS 12.7,16.5
 ISSUE:-4 TOLERANCE REMOVED ON DIMENSION 2.4

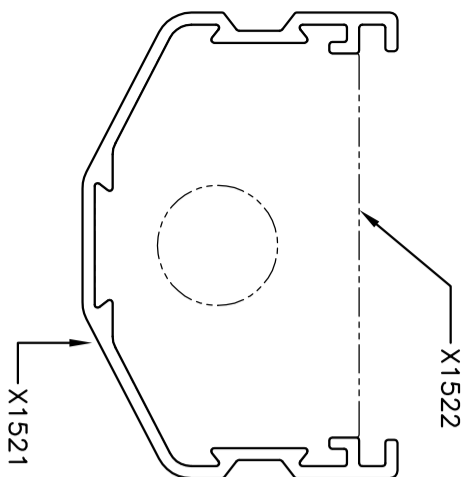
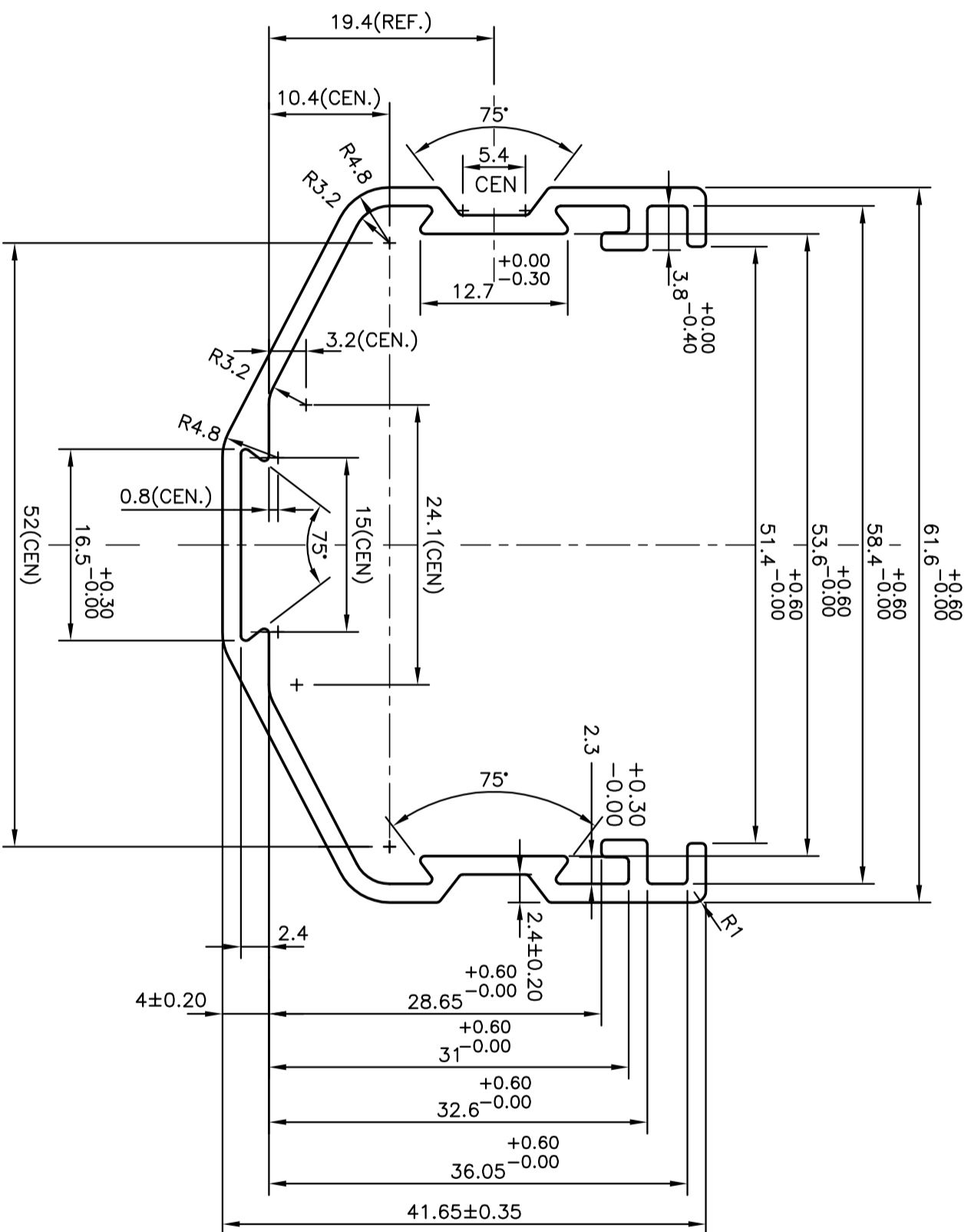

 <p>SYMBOL OF QUALITY AN ISO 9001 COMPANY</p>		<p>JINDAL ALUMINIUM LTD. BANGALORE-560073 (INDIA)</p>		NAME	DATE	
		DRAWN	J.P.KAUSHIK	21-09-2011	CHECKED	
<p>1. ALL DIMENSIONS ARE IN mm. 2. ROUND OFF ALL SHARP CORNERS WITH 0.40 mm. 3. TOLERANCES WILL BE AS PER ANSI:- H35-2009 UNLESS OTHERWISE SPECIFIED</p>		<p>PROSOURCE SOLUTIONS INC., CANADA</p>		APPROVED	S.S.GARG	22-09-2011
<p>PARTY'S NAME</p>		<p>TG-10A</p>		SCALE	2:1	
<p>PARTY'S DRAWING No.</p>		<p>6061 T6</p>		AREA mm ²	261.555	
<p>ALLOY & TEMPER</p>		<p>MISC. SECTION</p>		PERIMETER mm.	309.093	
<p>DESCRIPTION</p>		<p>PARTY'S DRAWING No.</p>		WEIGHT kg/m	0.706	
<p></p>		<p>DRAWING No.</p>		SECTION No.		
<p></p>		<p>P-11020</p>				
<p></p>		<p>X1521</p>				
<p></p>		<p>X1521(ISSUE-4)</p>				