

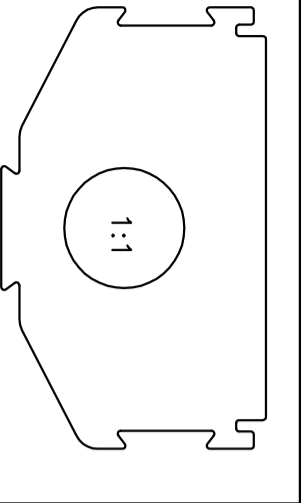

P-11021

X1522

ISSUE:-2 DIMENSIONS CHANGED
 ISSUE:-3 TOLERANCE CHANGED ON FOLLOWING DIMENSIONS 12.8,16.4
 ISSUE:-4 TOLERANCE REMOVED ON DIMENSION 2.4

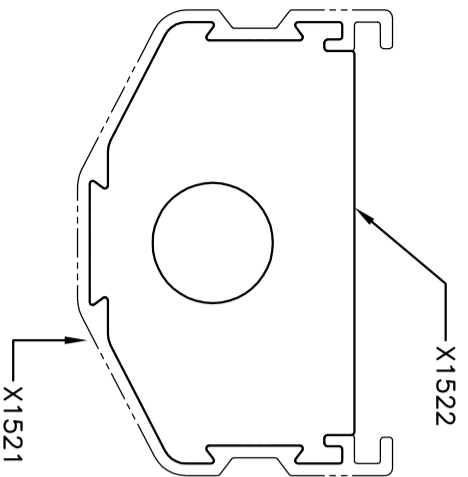
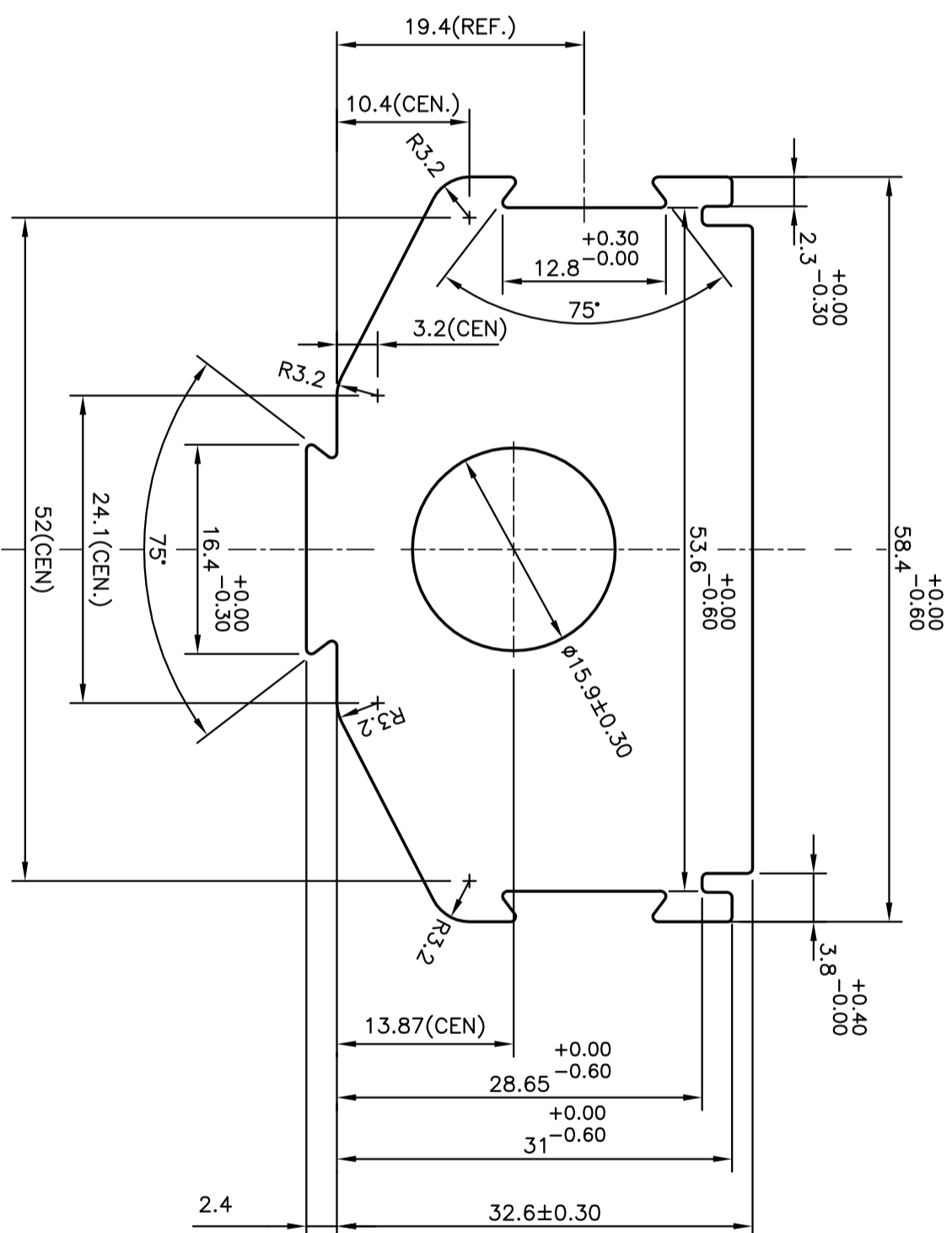

 <p>JINDAL ALUMINIUM LTD. BANGALORE-560073 (INDIA)</p>		NAME	J.P.KAUSHIK	DATE	21-09-2011
		DRAWN		CHECKED	
1. ALL DIMENSIONS ARE IN mm. 2. ROUND OFF ALL SHARP CORNERS WITH 0.40 mm. 3. TOLERANCES WILL BE AS PER ANSI:- H35-2009 UNLESS OTHERWISE SPECIFIED		APPROVED	S.S.GARG		22-09-2011
SYMBOL OF QUALITY AN ISO 9001 COMPANY		SCALE		2:1	
PARTY'S NAME PROSOURCE SOLUTIONS INC., CANADA		AREA	mm ²	1526.647	
PARTY'S DRAWING No. TG-20A		PERIMETER	mm.	196.448	
ALLOY & TEMPER 6061 T6		WEIGHT	kg/m	4.122	
DESCRIPTION MISC. SECTION		DRAWING No.		SECTION No.	
		P-11021		-	
		X1522		X1522(ISSUE-4)	