

P-9830

X1528

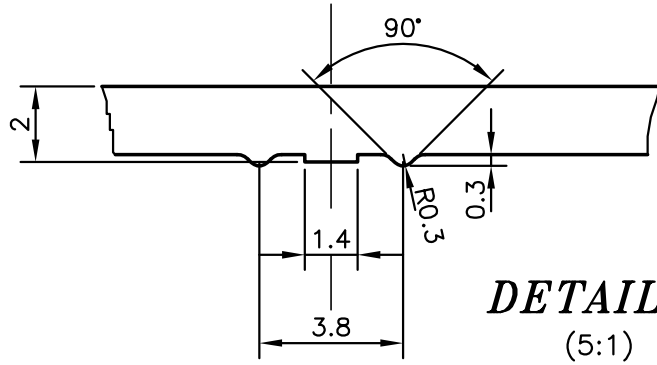

DETAIL "A"
(5:1)

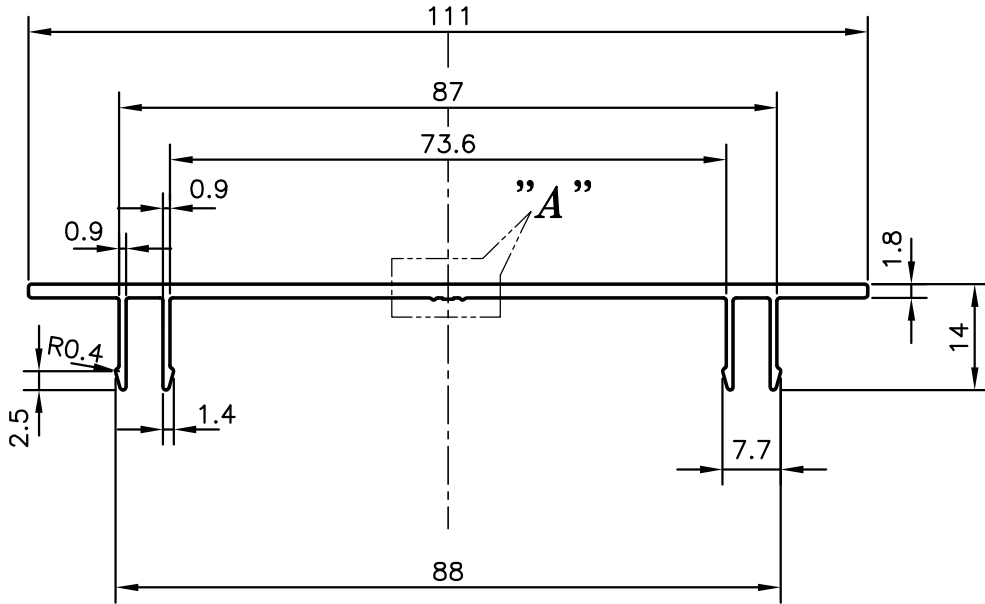

SYMBOL OF QUALITY
AN ISO 9001 COMPANY

JINDAL ALUMINIUM LTD.
BANGALORE-560073 (INDIA)

	NAME	DATE
DRAWN	J.P.KAUSHIK	24-02-2010
CHECKED		
APPROVED	S.S.GARG	16-07-2011
SCALE		1:1
AREA	mm ²	246.594
PERIMETER	mm.	321.309
WEIGHT	kg/m	0.666
DRAWING No.	SECTION No.	
P-9830	-	
X1528	X1528	

1. ALL DIMENSIONS ARE IN mm.
2. ROUND OFF ALL SHARP CORNERS WITH 0.40 mm.
3. TOLERANCES WILL BE AS PER BS:EN-755-9 UNLESS OTHERWISE SPECIFIED

PARTY'S NAME	APPLIED MATERIALS TRADING LTD., DUBAI
PARTY'S DRAWING No.	AS PER SAMPLE
ALLOY & TEMPER	6063 T6
DESCRIPTION	CLIP SECTION