

P-9860

X1534

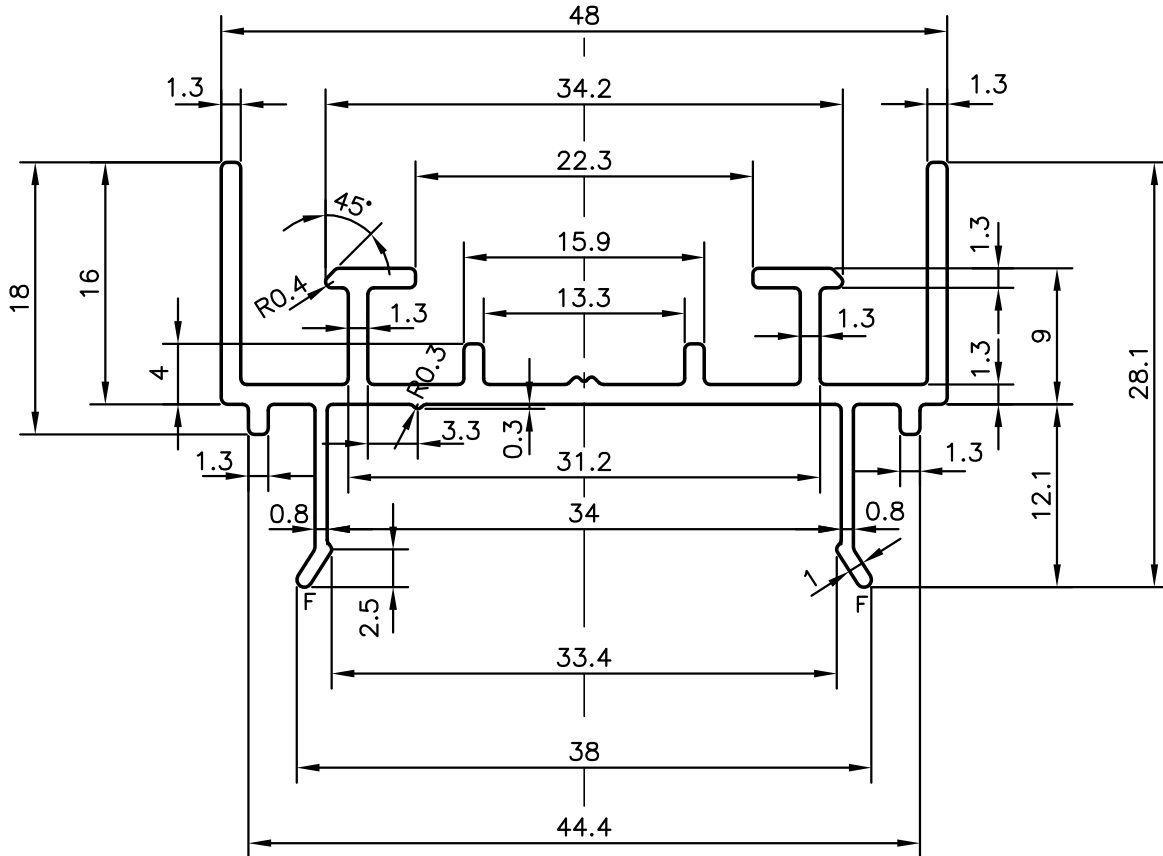

F = FULL RADIUS (2 PLACES)

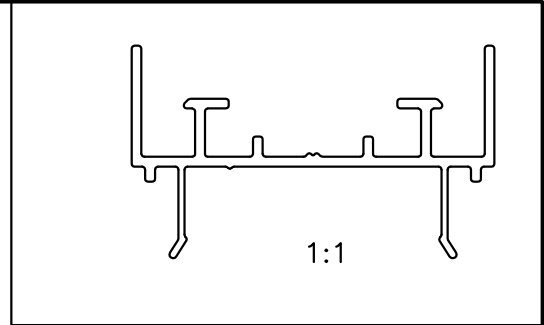
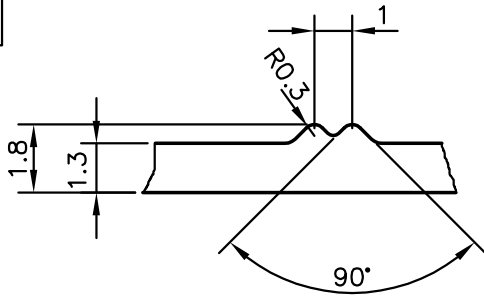

SYMBOL OF QUALITY
AN ISO 9001 COMPANY

JINDAL ALUMINIUM LTD.
BANGALORE-560073 (INDIA)

	NAME	DATE
DRAWN	J.P.KAUSHIK	03-03-2010
CHECKED		
APPROVED	S.S.GARG	16-07-2011
SCALE		2:1
AREA mm ²		166.444
PERIMETER mm.		267.777
WEIGHT kg/m		0.449
DRAWING No.	SECTION No.	
P-9860	-	
X1534	X1534	

1. ALL DIMENSIONS ARE IN mm.
2. ROUND OFF ALL SHARP CORNERS WITH 0.40 mm.
3. TOLERANCES WILL BE AS PER BS:EN-755-9 UNLESS OTHERWISE SPECIFIED

PARTY'S NAME	APPLIED MATERIALS TRADING LTD., DUBAI
PARTY'S DRAWING No.	AS PER SAMPLE
ALLOY & TEMPER	6063 T6
DESCRIPTION	MISC. SECTION