

P-9869

X1536

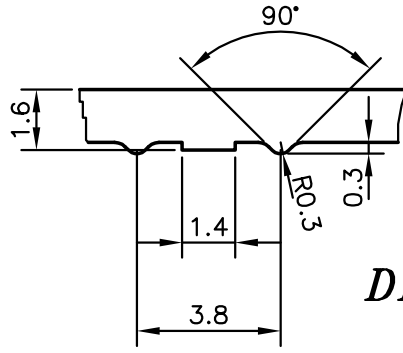

DETAIL "A"
(5:1)

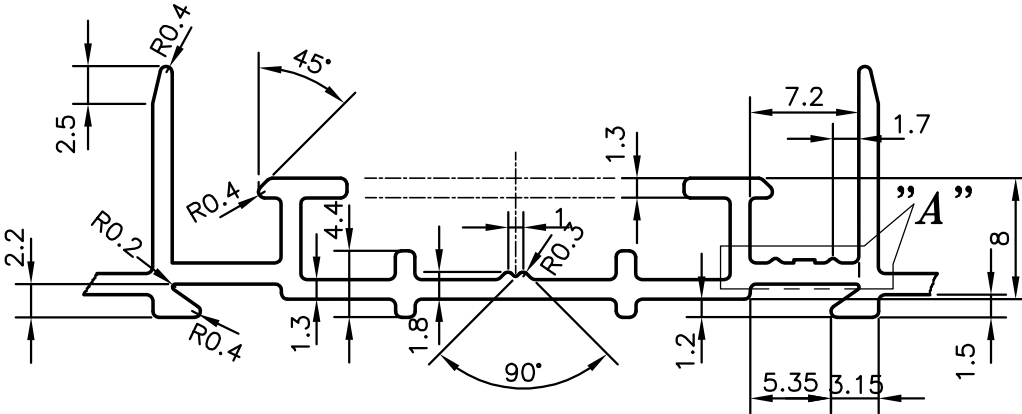
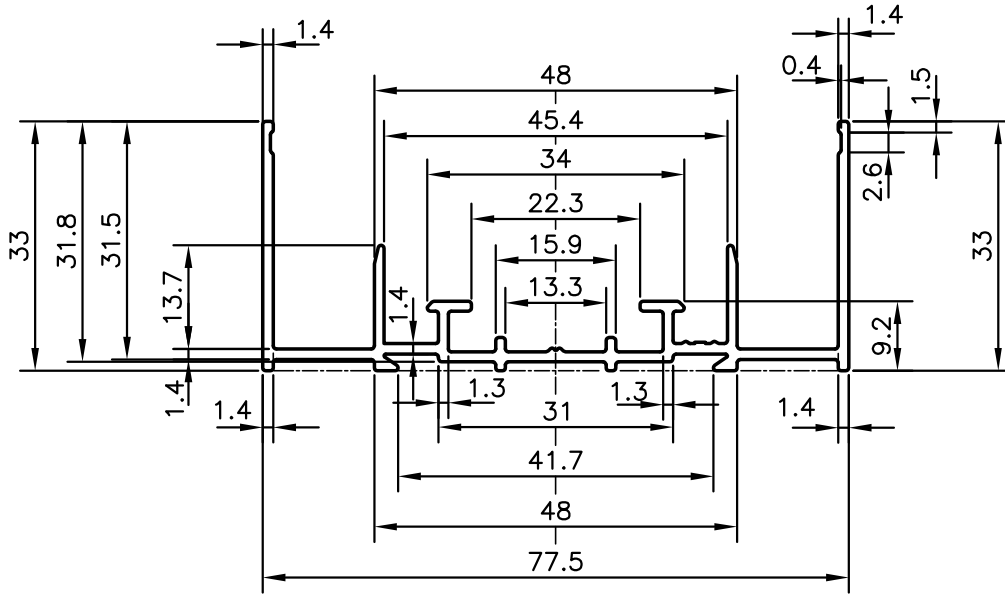

SYMBOL OF QUALITY
AN ISO 9001 COMPANY

JINDAL ALUMINIUM LTD.
BANGALORE-560073 (INDIA)

	NAME	DATE
DRAWN	J.P.KAUSHIK	22-03-2010
CHECKED		
APPROVED	S.S.GARG	16-07-2011
SCALE		1:1
AREA mm ²		272.389
PERIMETER mm.		397.53
WEIGHT kg/m		0.735
DRAWING No.	SECTION No.	
P-9869	-	
X1536	X1536	

1. ALL DIMENSIONS ARE IN mm.
2. ROUND OFF ALL SHARP CORNERS WITH 0.40 mm.
3. TOLERANCES WILL BE AS PER BS:EN-755-9 UNLESS OTHERWISE SPECIFIED

PARTY'S NAME	APPLIED MATERIALS TRADING LTD., DUBAI
PARTY'S DRAWING No.	AS PER SAMPLE
ALLOY & TEMPER	6063 T6
DESCRIPTION	MISC. CHANNEL