

P-11130-1

X1549

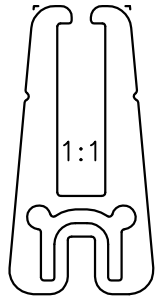
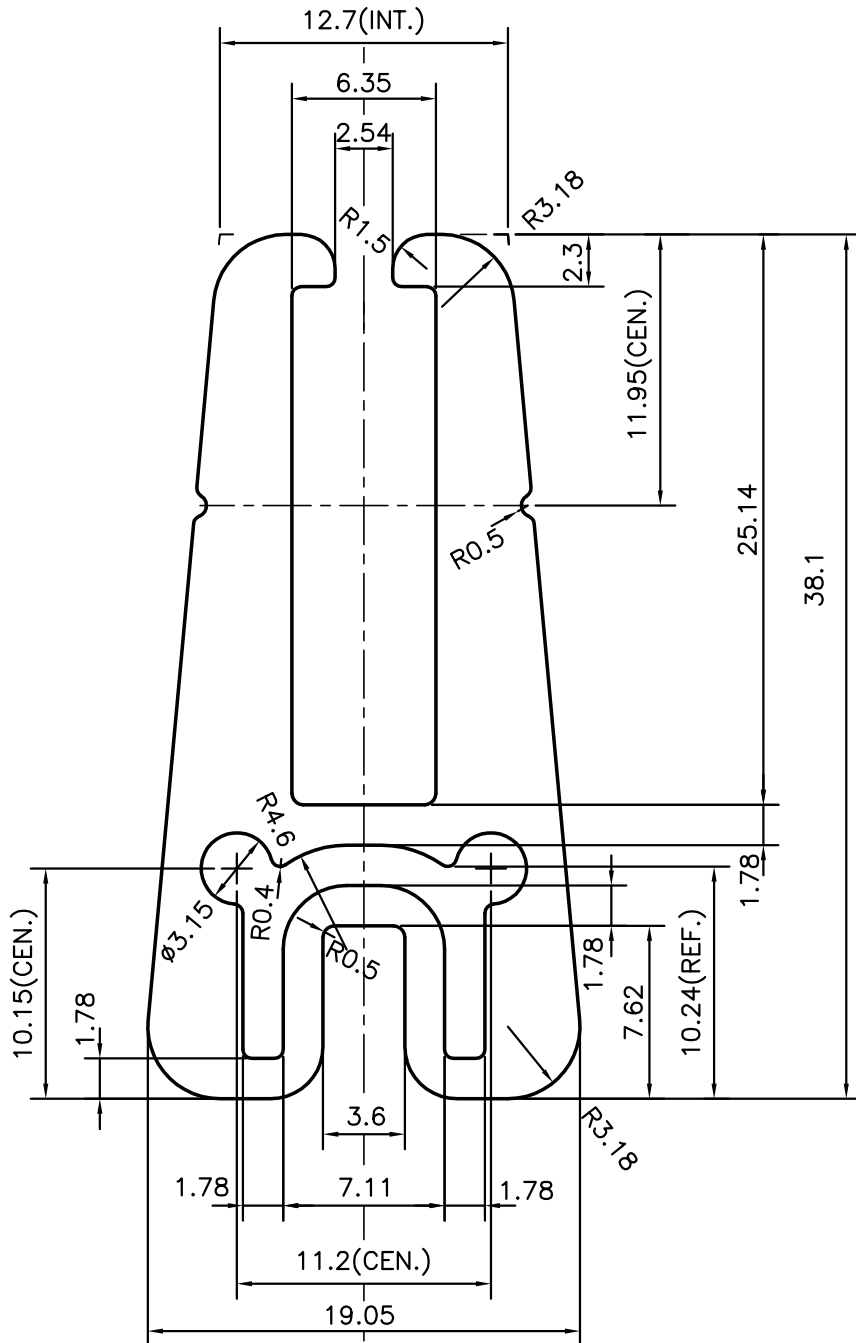

SYMBOL OF QUALITY
AN ISO 9001 COMPANY

JINDAL ALUMINIUM LTD.
BANGALORE-560073 (INDIA)

	NAME	DATE
DRAWN	J.P.KAUSHIK	04-08-2011
CHECKED		
APPROVED	S.S.GARG	29-09-2011
SCALE		3:1
AREA mm ²		368.646
PERIMETER mm.		172.414
WEIGHT kg/m		0.995
DRAWING No.	SECTION No.	
P-11130-1	-	
X1549	X1549	

1. ALL DIMENSIONS ARE IN mm.
2. ROUND OFF ALL SHARP CORNERS WITH 0.40 mm.
3. TOLERANCES WILL BE AS PER, ANSI H35.2-2009 UNLESS OTHERWISE SPECIFIED

PARTY'S NAME	DA-LITE SCREEN COMPANY, INC USA.
PARTY'S DRAWING No.	20600
ALLOY & TEMPER	6063 T6
DESCRIPTION	MISC. SECTION