

P-11131-1

X1550

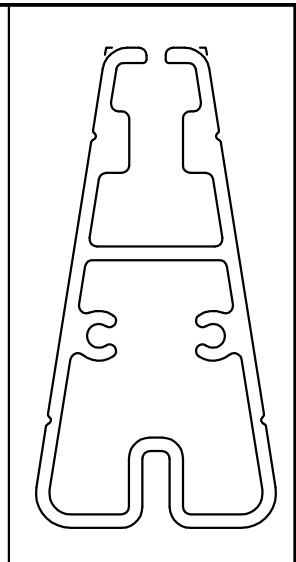

* = 1.0 RADIUS (24 PLACES)
 F = FULL RADIUS (4 PLACES)

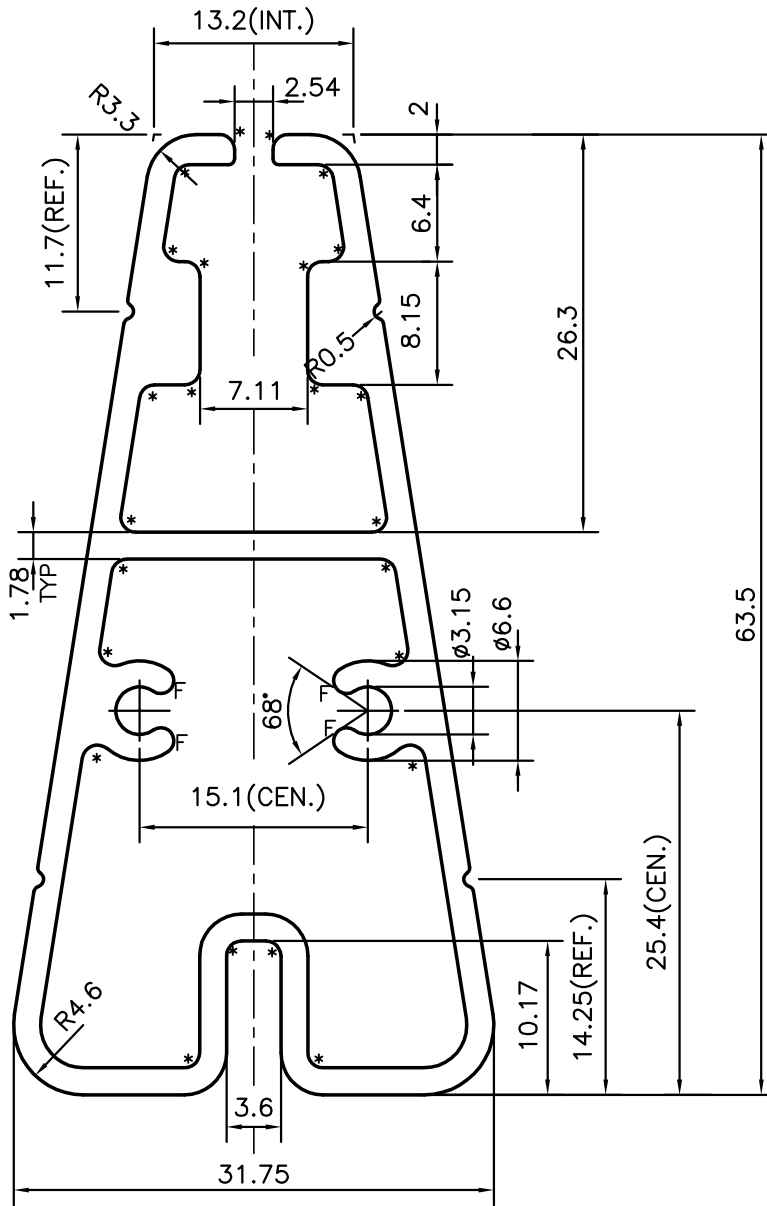

SYMBOL OF QUALITY
 AN ISO 9001 COMPANY

JINDAL ALUMINIUM LTD.
 BANGALORE-560073 (INDIA)

	NAME	DATE
DRAWN	J.P.KAUSHIK	04-08-2011
CHECKED		
APPROVED	S.S.GARG	29-09-2011
SCALE		2:1
AREA mm ²		445.144
PERIMETER mm.		268.607
WEIGHT kg/m		1.202
DRAWING No.	SECTION No.	
P-11131-1	-	
X1550	X1550	

1. ALL DIMENSIONS ARE IN mm.
2. ROUND OFF ALL SHARP CORNERS WITH 0.40 mm.
3. TOLERANCES WILL BE AS PER, ANSI H35.2-2009 UNLESS OTHERWISE SPECIFIED

PARTY'S NAME	DA-LITE SCREEN COMPANY, INC USA.
PARTY'S DRAWING No.	36408
ALLOY & TEMPER	6063 T6
DESCRIPTION	MISC. SECTION