

P-11365

X1565

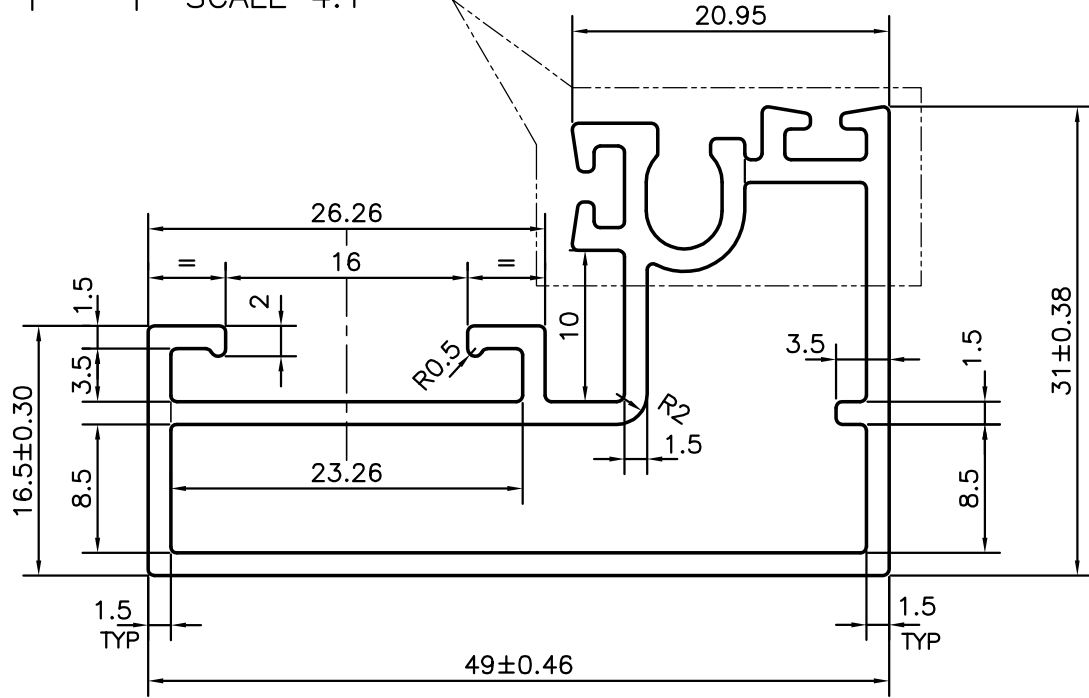
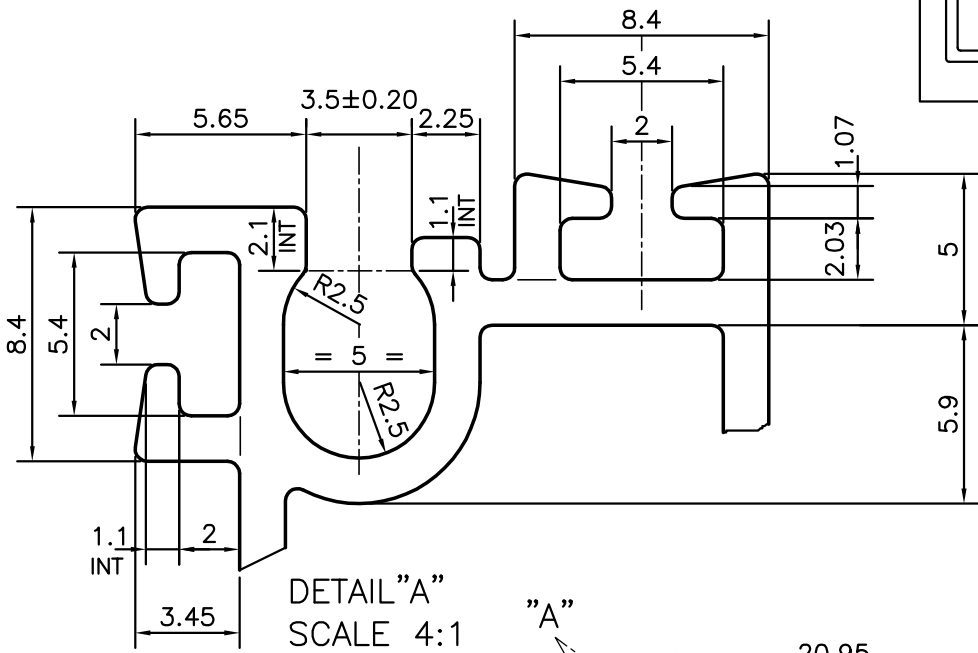
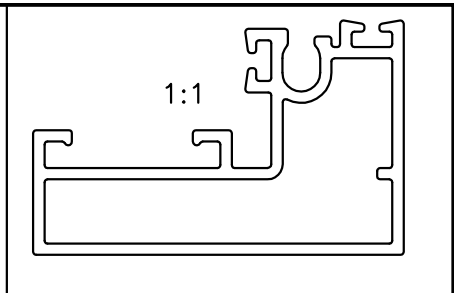

SYMBOL OF QUALITY  
AN ISO 9001 COMPANY

**JINDAL ALUMINIUM LTD.**  
BANGALORE-560073 (INDIA)

	NAME	DATE
DRAWN	J.P.KAUSHIK	03-12-2011
CHECKED		
APPROVED	S.S.GARG	13-12-2011
SCALE		2:1
AREA mm <sup>2</sup>		293.894
PERIMETER mm.		241.055
WEIGHT kg/m		0.794
DRAWING No.	SECTION No.	
P-11365	-	
X1565	X1565	

1. ALL DIMENSIONS ARE IN mm.
2. ROUND OFF ALL SHARP CORNERS WITH 0.40 mm.
3. TOLERANCES WILL BE AS PER, IS:6477-1983 UNLESS OTHERWISE SPECIFIED

PARTY'S NAME	AMBICA ALUMINIUM COMPANY, BANGALORE
PARTY'S DRAWING No.	AS PER DRAWING
ALLOY & TEMPER	HE9 WP
DESCRIPTION	MISC. SECTION