

P-11511-1

X1573

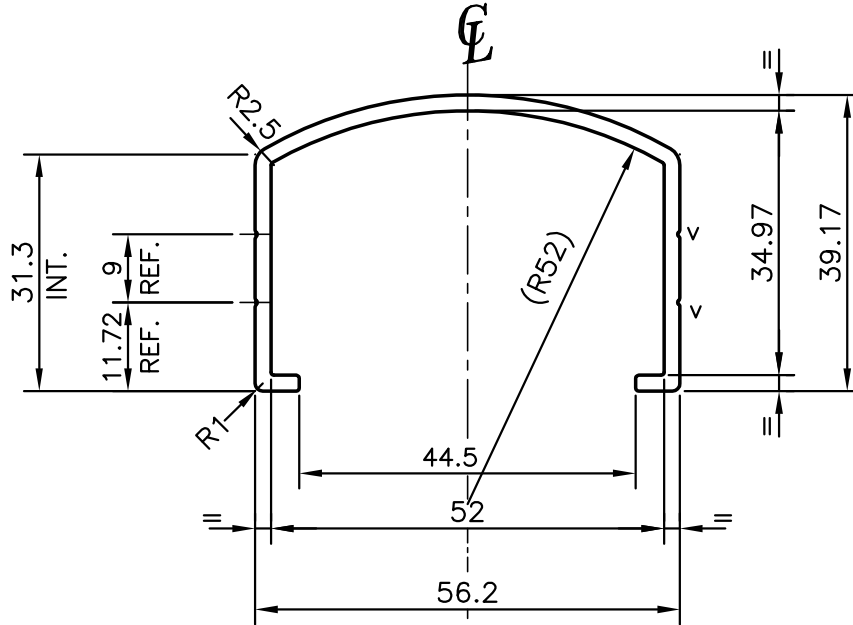

1. GENERAL WALL THICKNESS :- 2.10 mm.
2. V = VEE GROOVE 0.3x90° (4 PLACES)



SYMBOL OF QUALITY  
AN ISO 9001 COMPANY

**JINDAL ALUMINIUM LTD.**  
BANGALORE-560073 (INDIA)

	NAME	DATE
DRAWN	PARVESH	28-01-2012
CHECKED		
APPROVED	S.S.GARG	02-02-2012
SCALE		1:1
AREA mm <sup>2</sup>		262.115
PERIMETER mm.		253.811
WEIGHT kg/m		0.708
DRAWING No.	SECTION No.	
P-11511-1		
X1573	X1573	

1. ALL DIMENSIONS ARE IN mm.
2. ROUND OFF ALL SHARP CORNERS WITH 0.40 mm.
3. TOLERANCES WILL BE AS PER ANSI H35.2-2009 ,UNLESS OTHERWISE SPECIFIED

PARTY'S NAME	PROSOURCE INDL. SOLUTIONS, CANADA
PARTY'S DRAWING No.	AS PER DRAWING
ALLOY & TEMPER	6063 T5
DESCRIPTION	HAND RAIL SECTION