

P-11535-1

X1574

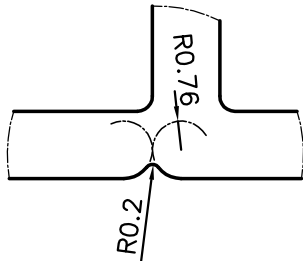

DETAIL OF 'B'
SCALE 2:1

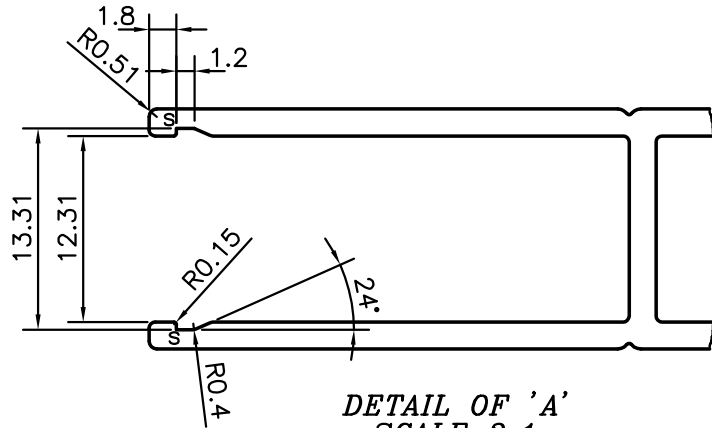

DETAIL OF 'A'
SCALE 2:1

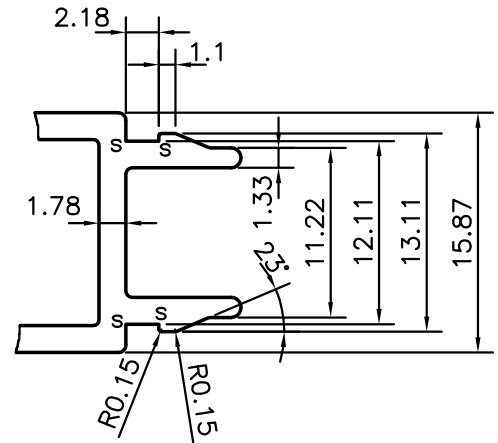
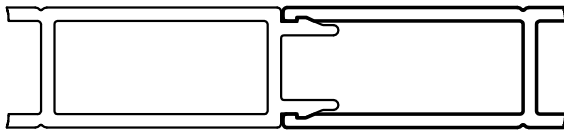

DETAIL OF 'A'
SCALE 2:1

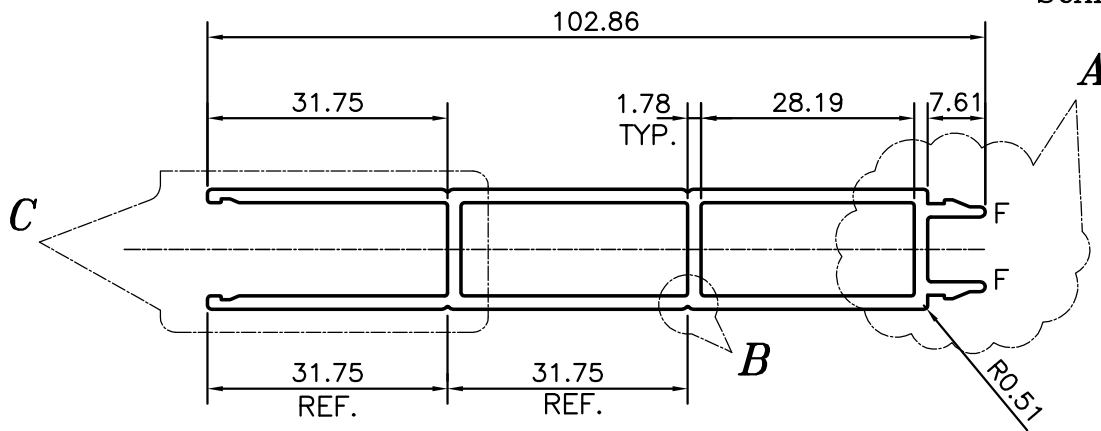

F = FULL RADIUS (2 PLACES)
s = SARP EDGE (6 PLACES)



SYMBOL OF QUALITY
AN ISO 9001 COMPANY

JINDAL ALUMINIUM LTD.
BANGALORE-560073 (INDIA)

	NAME	DATE
DRAWN	PARVESH	01-02-2012
CHECKED		
APPROVED	S.S.GARG	04-02-2012
SCALE		1:1
AREA mm ²		428.278
PERIMETER mm.		315.502
WEIGHT kg/m		1.156
DRAWING No.	SECTION No.	
P-11535-1		
X1574	X1574	

1. ALL DIMENSIONS ARE IN mm.
2. ROUND OFF ALL SHARP CORNERS WITH 0.40 mm.
3. TOLERANCES WILL BE AS PER ANSI H35.2-2009, UNLESS OTHERWISE SPECIFIED

PARTY'S NAME	PROSOURCE INDL. SOLUTIONS, CANADA
PARTY'S DRAWING No.	AS PER DRAWING
ALLOY & TEMPER	6063 T5
DESCRIPTION	MISC. SECTION