

P-12127-1

X1619

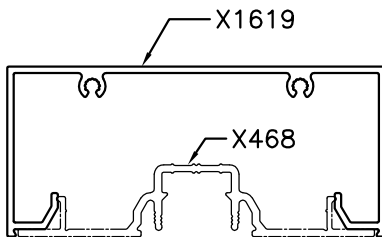

* = RADIUS 1.0 (4 PLACES)

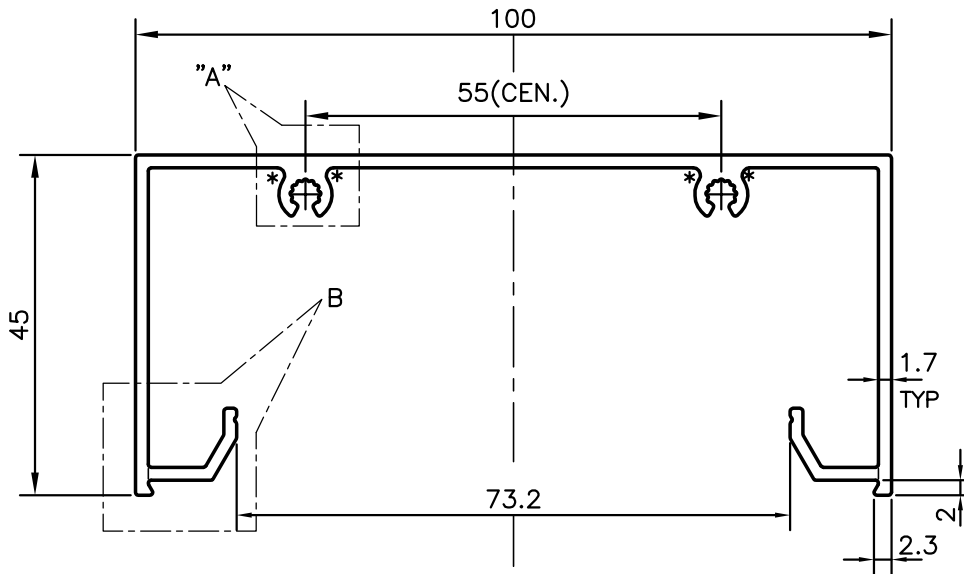
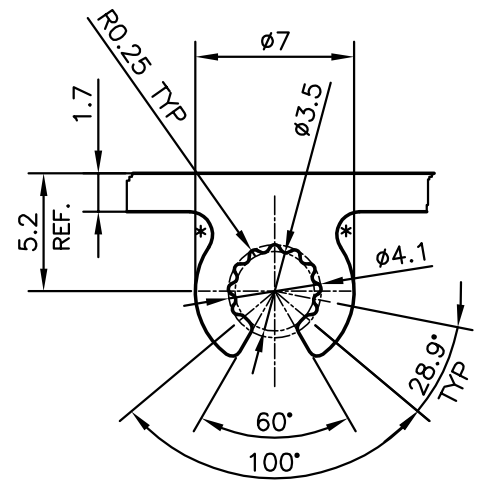
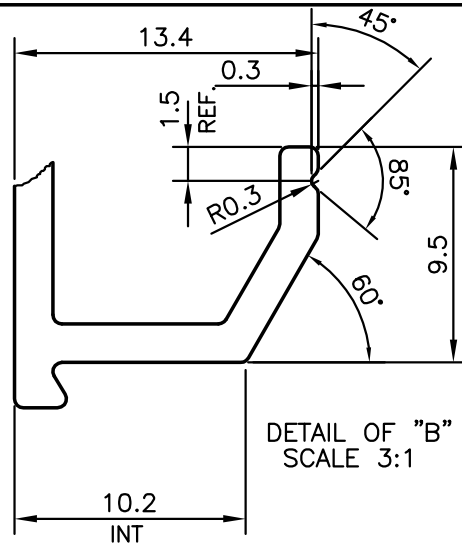

SYMBOL OF QUALITY
AN ISO 9001 COMPANY

JINDAL ALUMINIUM LTD.
BANGALORE-560073 (INDIA)

	NAME	DATE
DRAWN	J.P.KAUSHIK	27-10-2012
CHECKED		
APPROVED	S.S.GARG	12-11-2012
SCALE		1:1
AREA	mm ²	427.771
PERIMETER	mm.	491.223
WEIGHT	kg/m	1.155
DRAWING No.	SECTION No.	
P-12127-1	-	
X1619	X1619	

1. ALL DIMENSIONS ARE IN mm.
2. ROUND OFF ALL SHARP CORNERS WITH 0.40 mm.
3. TOLERANCES WILL BE AS PER BS:EN-755-9 UNLESS OTHERWISE SPECIFIED

PARTY'S NAME	AGARWAL CONSULTANCY SERVICES LTD., UK
PARTY'S DRAWING No.	AS PER SAMPLE
ALLOY & TEMPER	6063 T6
DESCRIPTION	MISC. SECTION