

P-12248-2

X1637

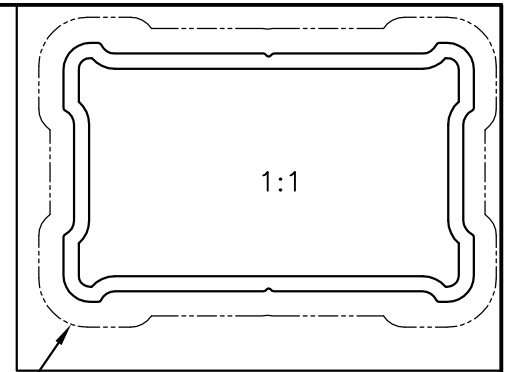

1:1

EXPOSED SURFACE BETTER FINISH REQUIRED

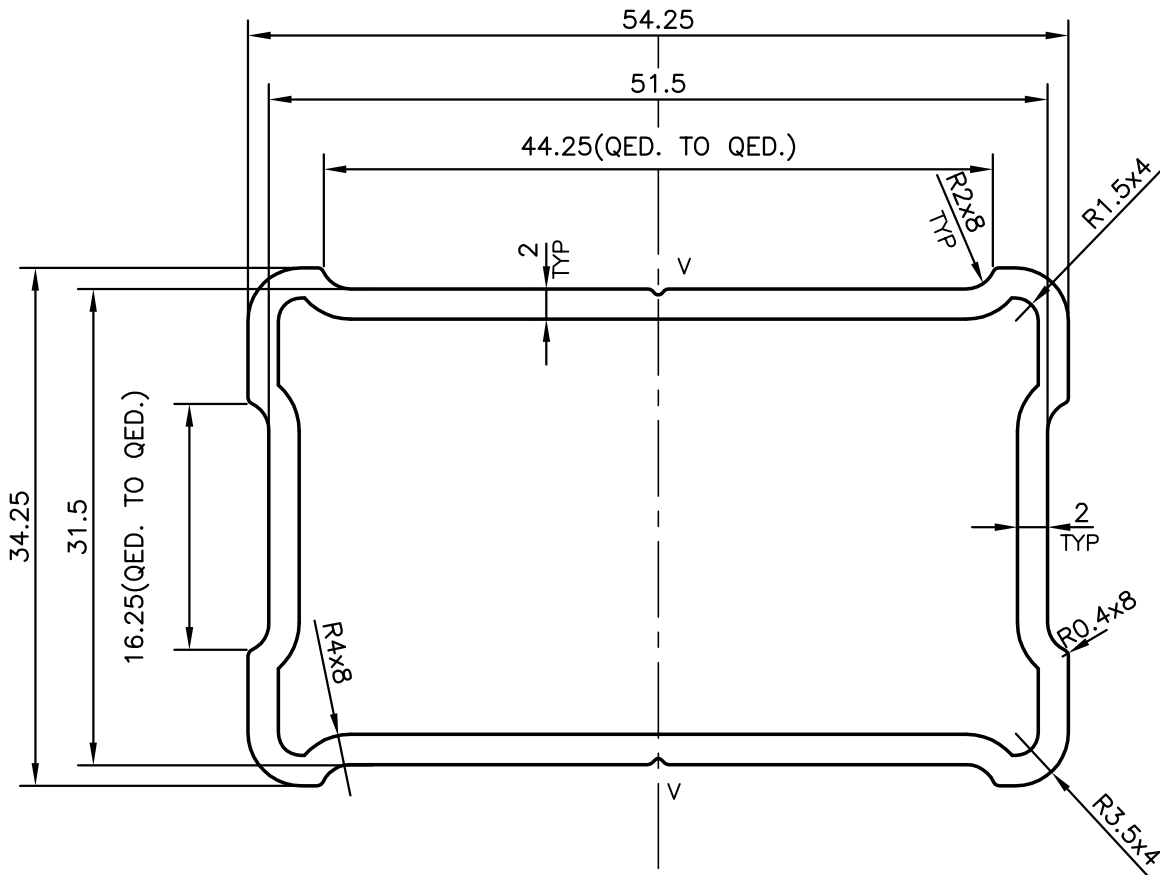

V = V GROOVE 0.4x90° (2 PLACES)



SYMBOL OF QUALITY
AN ISO 9001 COMPANY

JINDAL ALUMINIUM LTD.
BANGALORE-560073 (INDIA)

	NAME	DATE
DRAWN	J.P.KAUSHIK	26-11-2012
CHECKED		
APPROVED	S.S.GARG	30-11-2012
SCALE		2:1
AREA mm ²		336.632
PERIMETER mm.		175.923
WEIGHT kg/m		0.909
DRAWING No.	SECTION No.	
P-12248-2	-	
X1637	X1637	

1. ALL DIMENSIONS ARE IN mm.
2. ROUND OFF ALL SHARP CORNERS WITH 0.40 mm.
3. TOLERANCES WILL BE AS PER, AUS/NZ1866.1976.1997 UNLESS OTHERWISE SPECIFIED

PARTY'S NAME	MAYFAIR METALS, AUSTRALIA
PARTY'S DRAWING No.	MODIFICATION OF SECTION NoX357 & REQUIREMENT
ALLOY & TEMPER	6106 T6
DESCRIPTION	MISC. SECTION