

P-12302-1

X1645

EXPOSED SURFACE

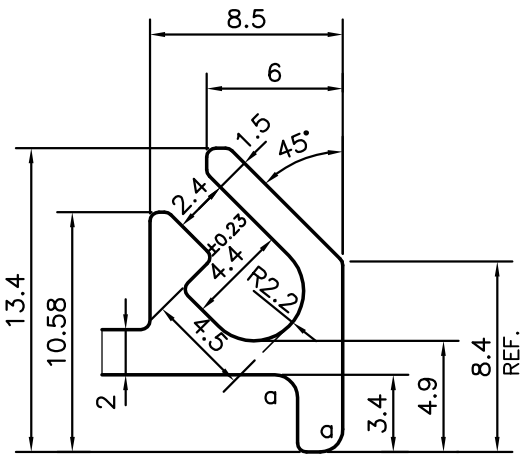
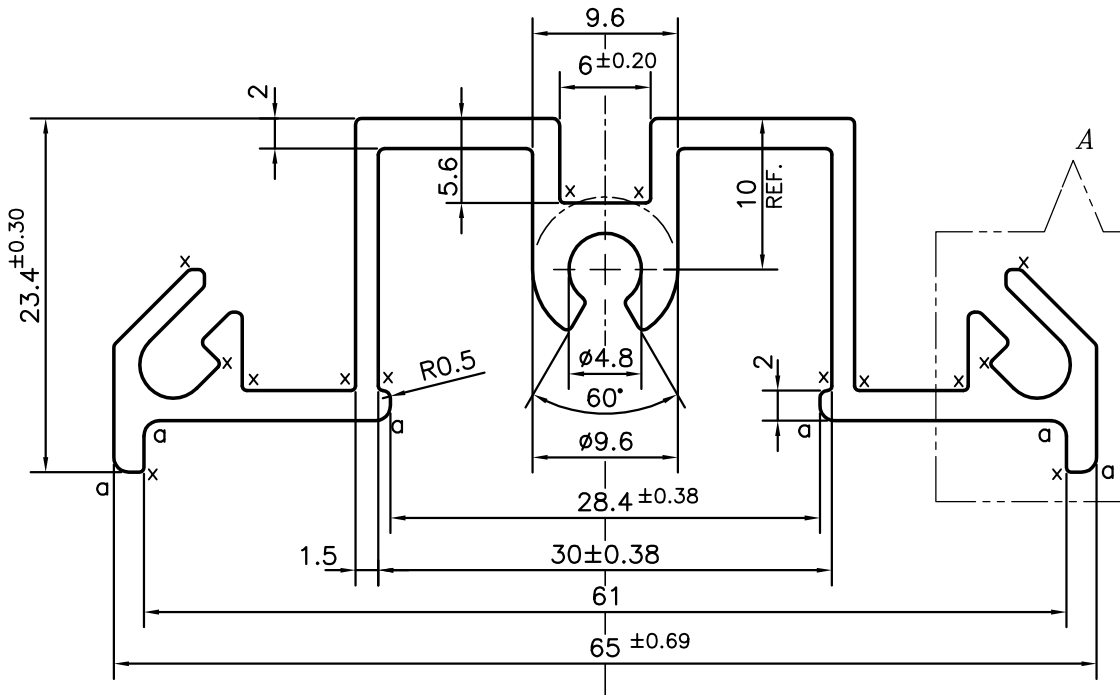
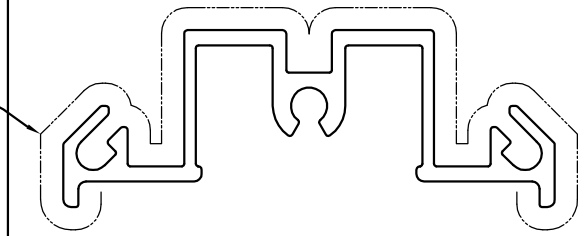

DETAIL OF "A"
SCALE:- 3:1

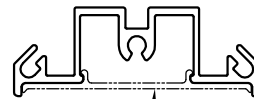

X1647

a = RADIUS 1 mm. (6 PLACES)
X = RADIUS 0.3 mm. (14 PLACES)



SYMBOL OF QUALITY
AN ISO 9001 COMPANY

JINDAL ALUMINIUM LTD.
BANGALORE-560073 (INDIA)

	NAME	DATE
DRAWN	PARVESH	11-12-2012
CHECKED		
APPROVED	S.S.GARG	21-12-2012
SCALE		2:1
AREA mm ²		303.05
PERIMETER mm.		317.649
WEIGHT kg/m		0.818
DRAWING No.	SECTION No.	
P-12302-1	-	
X1645	X1645	

1. ALL DIMENSIONS ARE IN mm.
2. ROUND OFF ALL SHARP CORNERS WITH 0.40 mm.
3. TOLERANCES WILL BE AS PER IS:3965-1981 , UNLESS OTHERWISE SPECIFIED

PARTY'S NAME	FUEGO FURNITURE PVT. LTD., BANGALORE
PARTY'S DRAWING No.	SECTION 31
ALLOY & TEMPER	HE9 WP
DESCRIPTION	FURNITURE SECTION