

P-12706-1

X1671

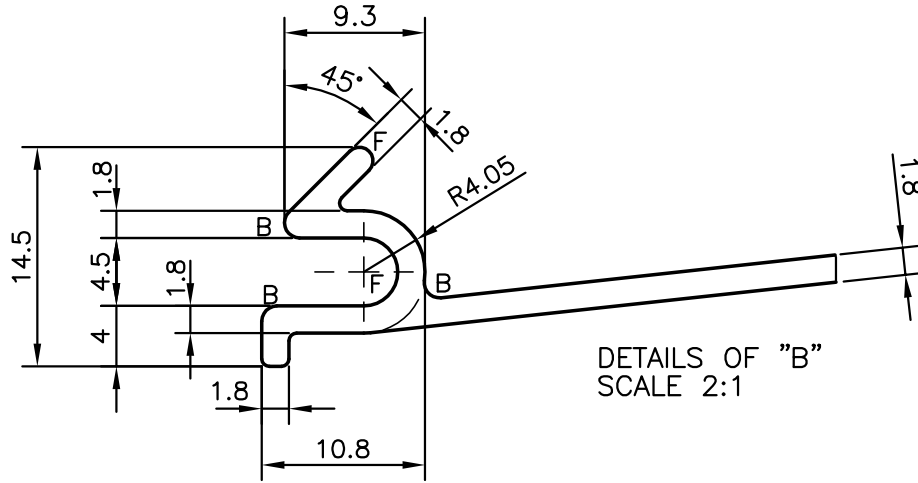

DETAILS OF "B"
SCALE 2:1

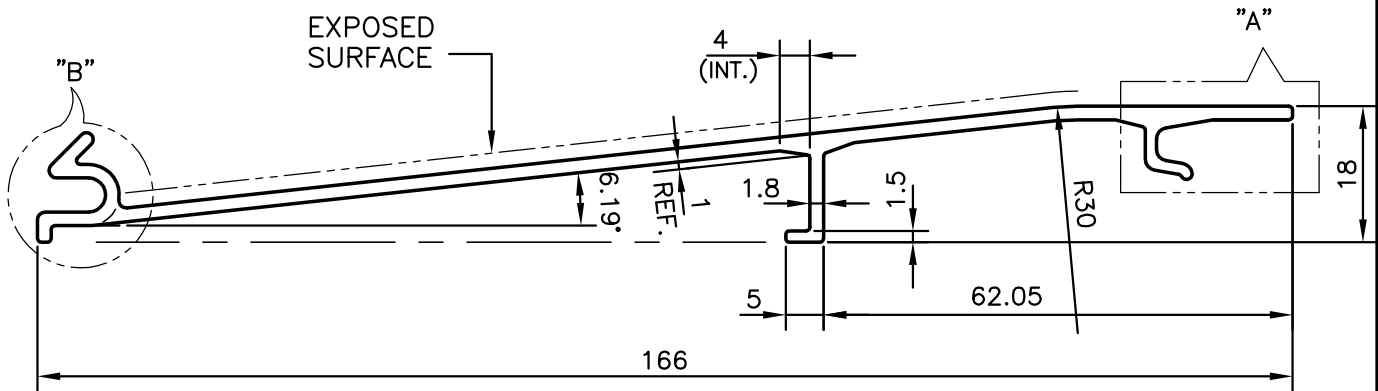

DETAILS OF "A"
SCALE 2:1

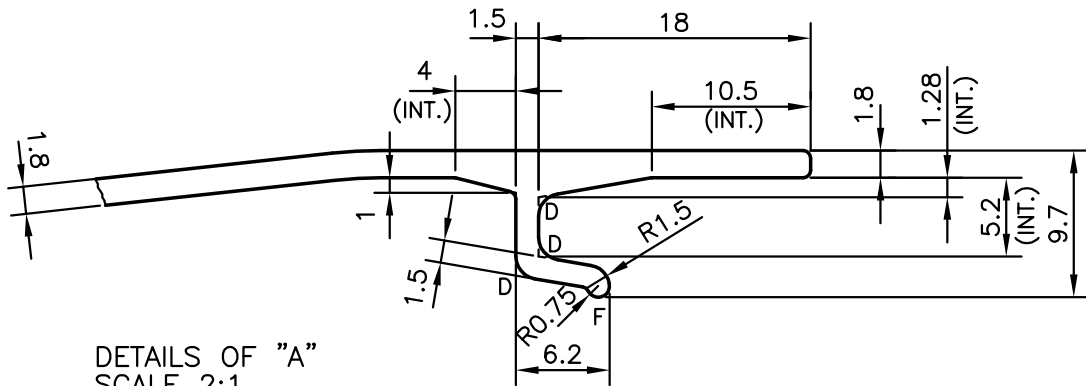

B = 1 mm RADIUS (3 PLACES)
F = FULL RADIUS (3 PLACES)
D = 1.5 mm RADIUS (3 PLACES)



SYMBOL OF QUALITY
AN ISO 9001 COMPANY

JINDAL ALUMINIUM LTD.
BANGALORE-560073 (INDIA)

	NAME	DATE
DRAWN	SRIVATHSA	08-05-2013
CHECKED		
APPROVED	S.S.GARG	16-05-2013
SCALE		1:1
AREA mm ²		392.177
PERIMETER mm.		418.601
WEIGHT kg/m		1.059
DRAWING No.	SECTION No.	
P-12706-1	-	
X1671	X1671	

1. ALL DIMENSIONS ARE IN mm.
2. ROUND OFF ALL SHARP CORNERS WITH 0.50 mm.
3. TOLERANCES WILL BE AS PER BS:EN-755-9 , UNLESS OTHERWISE SPECIFIED

PARTY'S NAME	PAYNES WHOLESALERS LTD, NEW ZEALAND
PARTY'S DRAWING No.	SKETCH 3 & AS PER REQUIREMENT
ALLOY & TEMPER	6060 T5
DESCRIPTION	CLADDING SECTION