

P-12804

X1677

ENSURE TIGHT FITMENT WITH SECTION X1676.

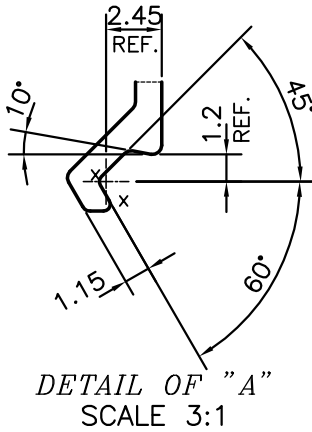
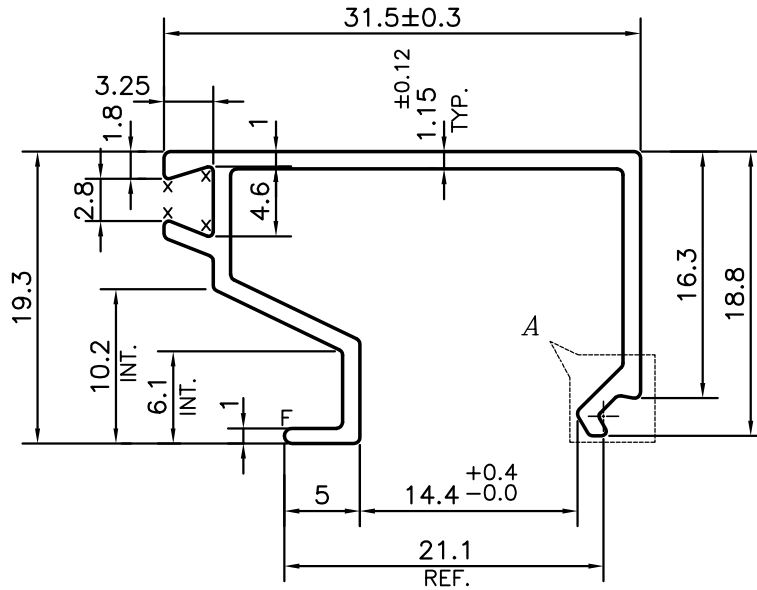
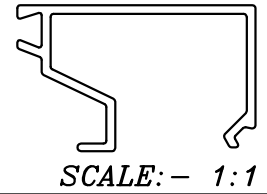

X1676

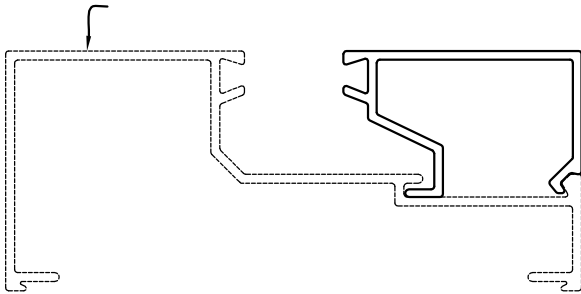

X = RADIUS 0.3 mm. (6 PLACES)
F = FULL RADIUS (1 PLACES)

TOLERANCE CHART CD = CIRCUMSCRIBING CIRCLE

DIMENSION	CD ≤ 100	100 < CD ≤ 200	200 < CD ≤ 300	300 < CD ≤ 500
UPTO 10mm	±0.25	±0.30	±0.35	±0.40
10.0 - 25.0	±0.30	±0.40	±0.50	±0.60
25.0 - 50.0	±0.50	±0.60	±0.80	±0.90
50.0 - 100	±0.70	±0.90	±1.10	±1.30
100 - 150	-	±1.10	±1.30	±1.50
150 - 200	-	±1.3	±1.50	±1.80
200 - 300	-	-	±1.70	±2.10
300 - 450	-	-	-	±2.80



SYMBOL OF QUALITY
AN ISO 9001 COMPANY

JINDAL ALUMINIUM LTD.
BANGALORE-560073 (INDIA)

	NAME	DATE
DRAWN	PARVESH	24-05-2013
CHECKED		
APPROVED	S.S.GARG	31-05-2013

- ALL DIMENSIONS ARE IN mm.
- ROUND OFF ALL SHARP CORNERS WITH 0.40 mm.
- TOLERANCES WILL BE AS PER BS:EN-755-9, UNLESS OTHERWISE SPECIFIED

SCALE	2:1
AREA mm ²	95.154
PERIMETER mm.	164.183
WEIGHT kg/m	0.257

PARTY'S NAME COMARK LANKA (PVT.) LIMITED, COLOMBO

DRAWING No. SECTION No.

PARTY'S DRAWING No. 9056

P-12804 -

ALLOY & TEMPER 6063 T6

X1677 X1677

DESCRIPTION

GLAZING CUR SECTION