

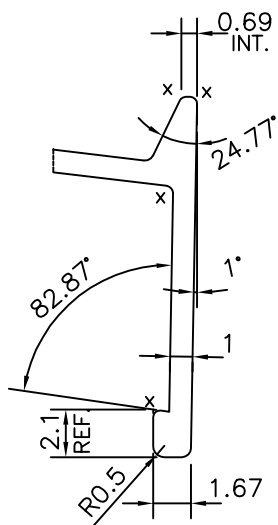

P-13193-1

X1706

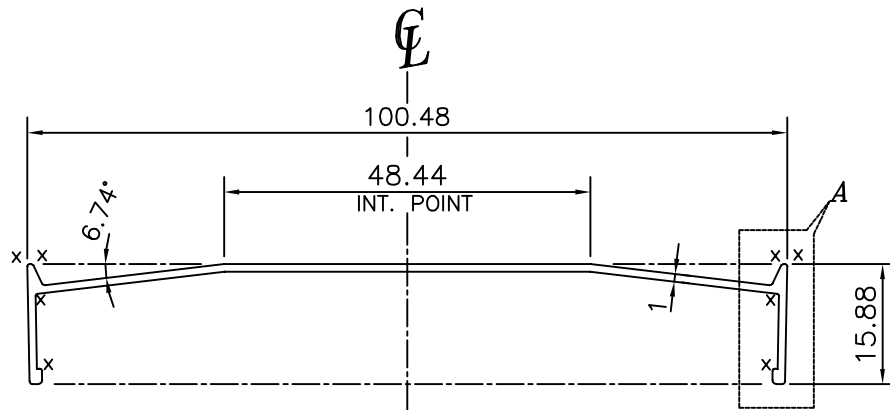

DETAIL OF "A"
SCALE 3:1

X = RADIUS 0.3 mm. (8 PLACES)

 SYMBOL OF QUALITY AN ISO 9001 COMPANY	JINDAL ALUMINIUM LTD. BANGALORE-560073 (INDIA)	NAME		DATE
		DRAWN	PARVESH	23-11-2013
1. ALL DIMENSIONS ARE IN mm. 2. ROUND OFF ALL SHARP CORNERS WITH 0.40 mm. 3. TOLERANCES WILL BE AS PER ANSI H35.2-2009, UNLESS OTHERWISE SPECIFIED		CHECKED		
		APPROVED	S.S.GARG	28-11-2013
PARTY'S NAME PROSOURCE INDL. SOLUTIONS, CANADA		SCALE		1:1
		AREA mm ²		135.209
PARTY'S DRAWING No. AS PER DRAWING		PERIMETER mm.		261.843
		WEIGHT kg/m		0.365
ALLOY & TEMPER 6063 T5		DRAWING No.	SECTION No.	
		P-13193-1	-	
DESCRIPTION ARCHITECTURAL SECTION-CLIP COVER		X1706		X1706