

P-13465-1

X1754

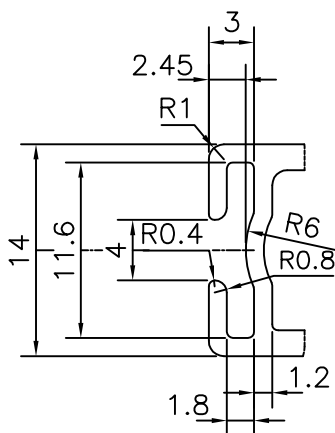

DETAIL OF "A"
SCALE 2:1

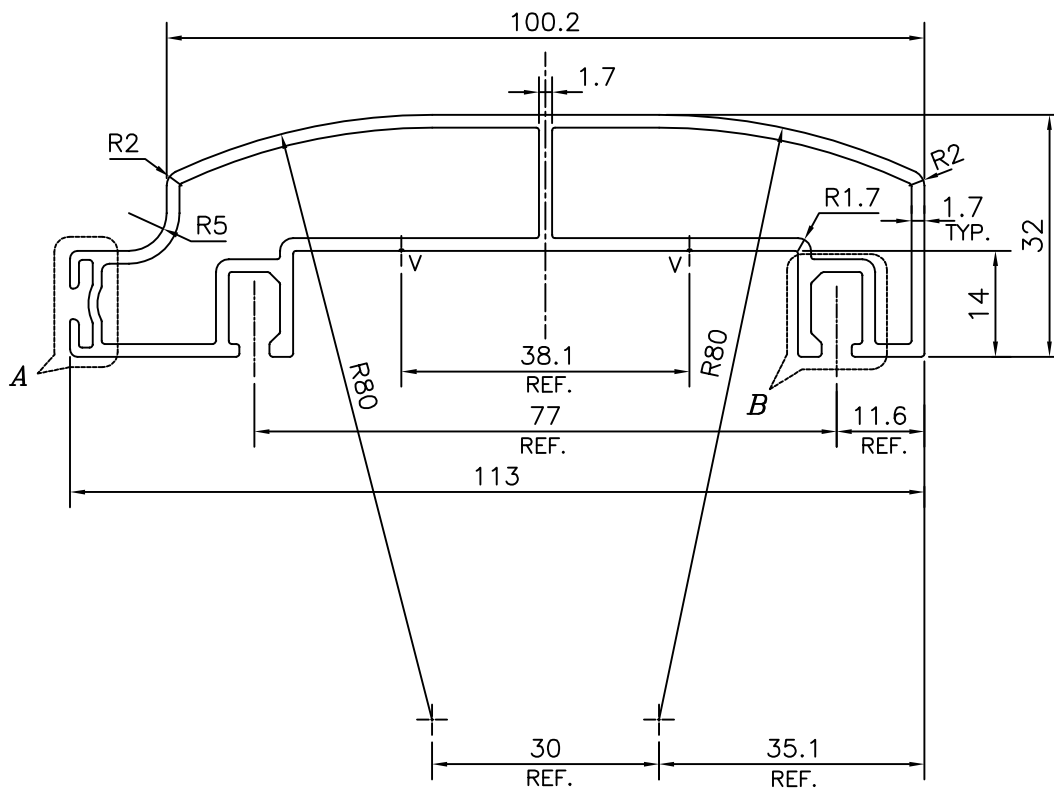
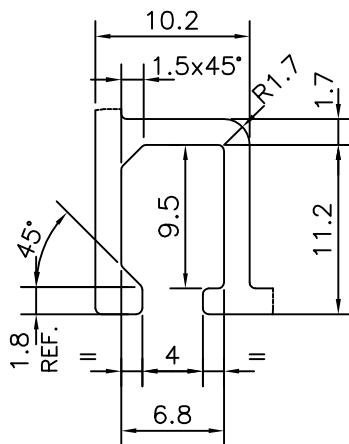

DETAIL OF "B"
SCALE 2:1

V = VEE GROOVE 0.25x90° (2 PLACES)



SYMBOL OF QUALITY
AN ISO 9001 COMPANY

JINDAL ALUMINIUM LTD.
BANGALORE-560073 (INDIA)

	NAME	DATE
DRAWN	PARVESH	15-03-2014
CHECKED		
APPROVED	S.S.GARG	01-04-2014
SCALE		1:1
AREA mm ²		576.786
PERIMETER mm.		370.601
WEIGHT kg/m		1.557
DRAWING No.	SECTION No.	
P-13465-1	-	
X1754	X1754	

1. ALL DIMENSIONS ARE IN mm.
2. ROUND OFF ALL SHARP CORNERS WITH 0.40 mm.
3. TOLERANCES WILL BE AS PER ANSI:H35.2-2009 , UNLESS OTHERWISE SPECIFIED

PARTY'S NAME	IMT LTD., CANADA
PARTY'S DRAWING No.	2011
ALLOY & TEMPER	6063 T6
DESCRIPTION	MISC. SECTION