

P-13503-2

X1762

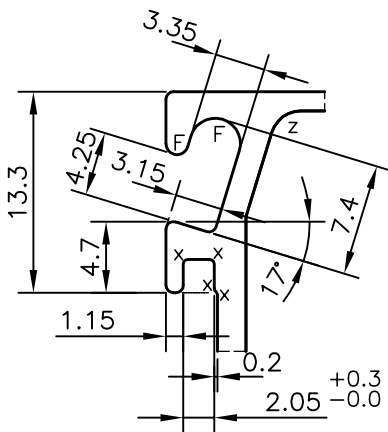

DETAIL OF "A"
SCALE 2:1

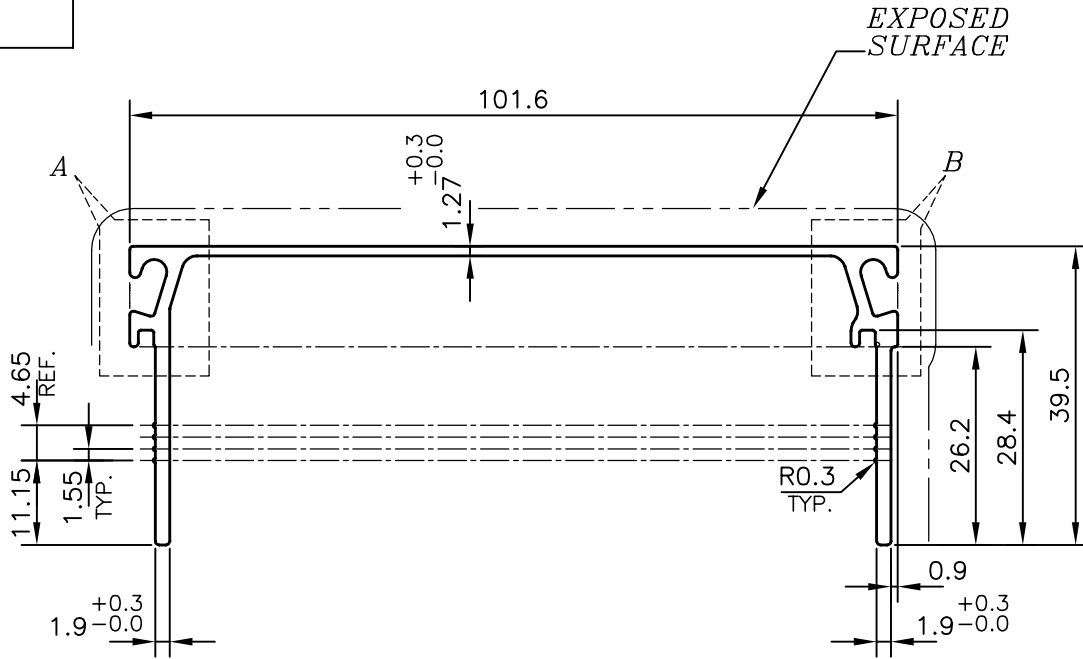
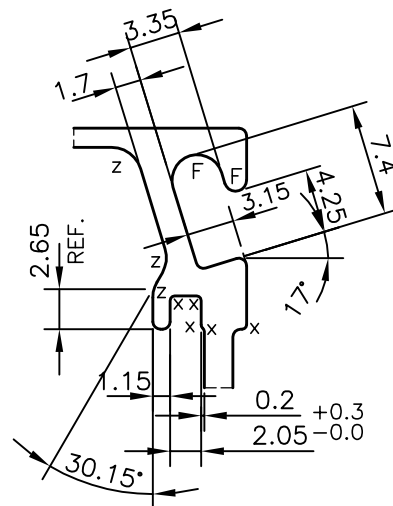

DETAIL OF "B"
SCALE 2:1

F = FULL RADIUS (4 PLACES)
X = RADIUS 0.3 mm. (9 PLACES)
Z = RADIUS 2 mm. (4 PLACES)



SYMBOL OF QUALITY
AN ISO 9001 COMPANY

JINDAL ALUMINIUM LTD.
BANGALORE-560073 (INDIA)

	NAME	DATE
DRAWN	PARVESH	09-05-2014
CHECKED		
APPROVED	S.S.GARG	13-05-2014

1. ALL DIMENSIONS ARE IN mm.
2. ROUND OFF ALL SHARP CORNERS WITH 0.50 mm.
3. TOLERANCES WILL BE AS PER ANSI:H35.2-2009 , UNLESS OTHERWISE SPECIFIED

SCALE	1:1
AREA mm ²	313.764
PERIMETER mm.	386.57
WEIGHT kg/m	0.847

PARTY'S NAME	WHITE DISTRIBUTOR LLC, USA
PARTY'S DRAWING No.	AS PER AUTOCAD DRAWING (DATED 24-04-2014)
ALLOY & TEMPER	6005 T6
DESCRIPTION	MISC. SECTION

DRAWING No.	SECTION No.
P-13503-2	-
X1762	X1762